

Toshiba BiCD Process Integrated Circuits Silicon Monolithic

# TB67S579FTG

BiCD Constant Current 2-Phase Bipolar Stepper Motor Driver IC

## 1. Overview

TB67S579FTG is a PWM chopper-type 2-phase bipolar drive system stepping motor driver IC. The BiCD process is used to withstand an output voltage of 40 V and a maximum current of 2.0 A.

In addition, a built-in regulator for IC operation allows the motor to be driven by a single VM power supply.

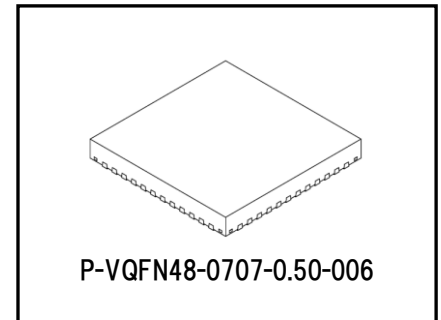

Weight: 0.137 g (Typ.)

## 2. Features

- Monolithic IC by BiCD Process
- Bipolar Stepper Motor Drive ICs
- Equipped with the Advanced Current Detect System (ACDS) function, PWM constant current drive without an external current-sense resistor
- Equipped with Advanced Dynamic Mixed Decay function to achieve high-efficiency PWM constant-current drive (when  $\mu$  step is selected)
- Clock Input Control
- Full, Half,  $1/4$ ,  $1/8$ ,  $1/16$ ,  $1/32$  step excitation (when  $\mu$  step is selected)
- Equipped with Active Gain Control (AGC)
- By using Continuous Micro-stepping, it is possible to reduce vibration when driving a motor
- Automatic Wave Generation System (AWGS) Achieves  $\mu$  Step ( $1/32$ Step) with CLK such as Full step
- BiCD structure : DMOSFET used as output power transistor
- High withstand voltage and high current: 40 V / 2.0 A (absolute maximum)
- Integrated Over-Temperature Detection (TSD), Over-Current Detection (ISD), Open-Load Detection (OPD), Stall Detection, and Under-Supply Voltage Detection (UVLO)
- Reduction of External Components for Charge Pumps
- Package: QFN48(7mmx7mm)

Start of mass production of products  
2025-09

## 3. Block Diagram

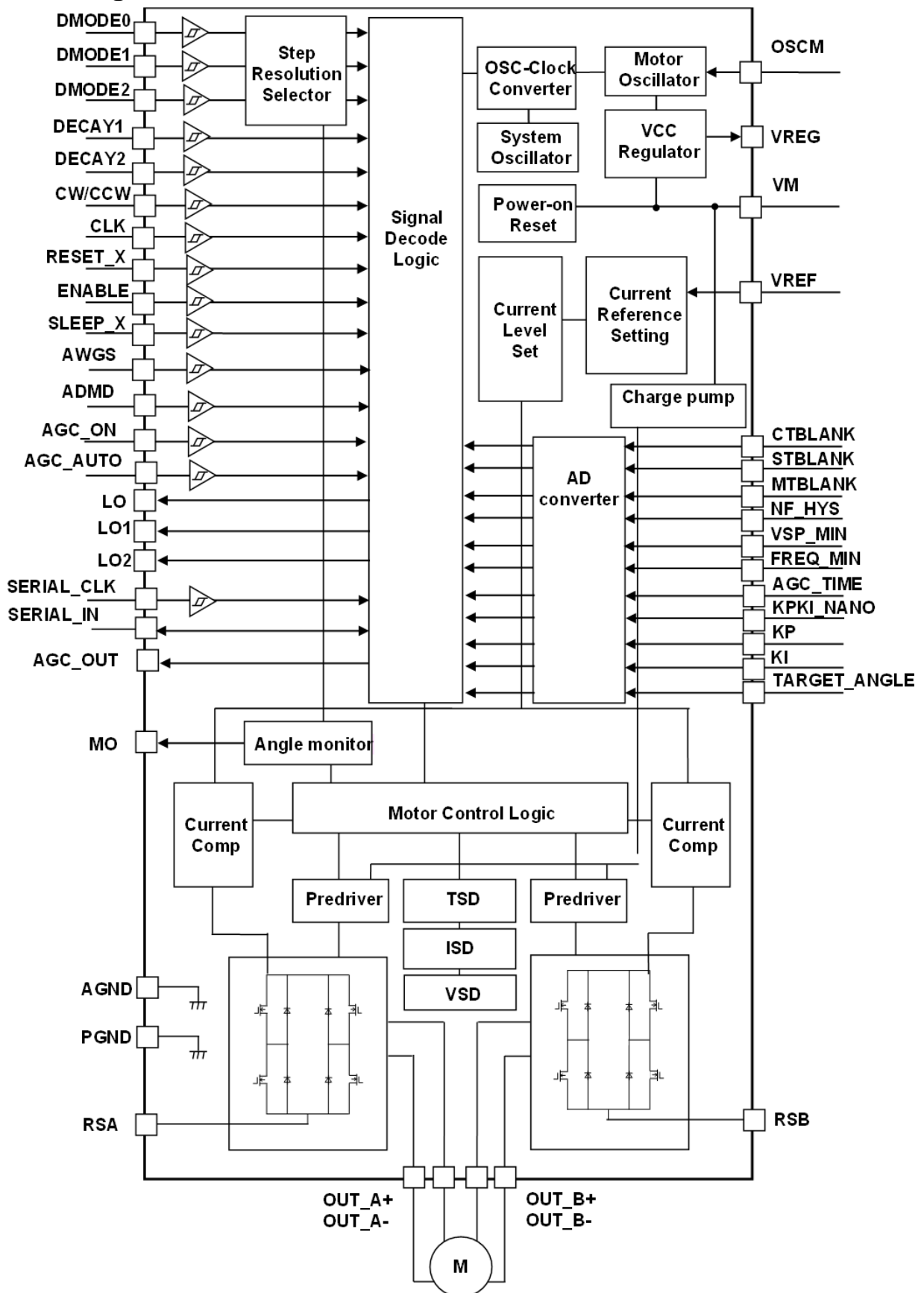
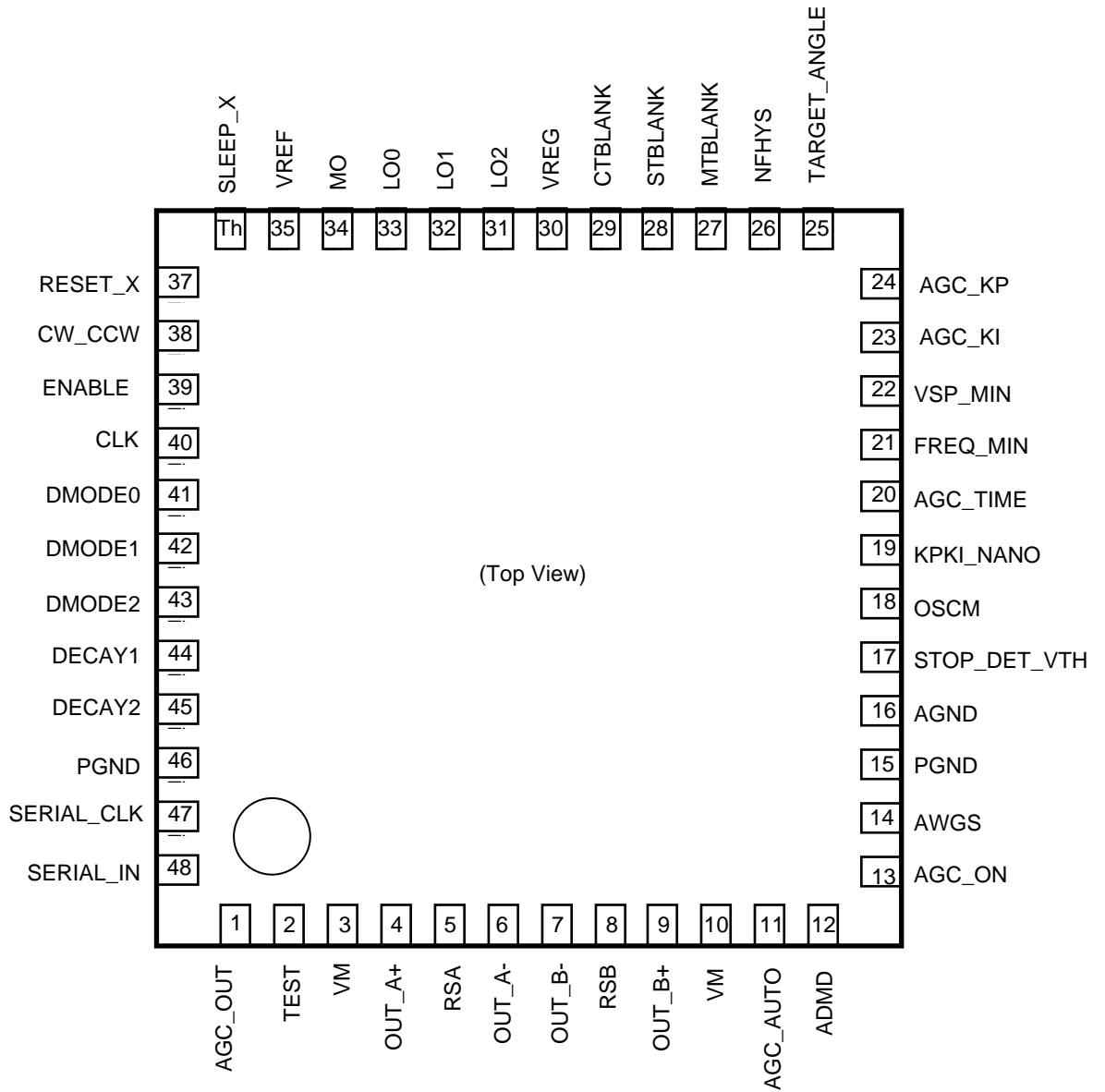

**Figure 3 Block diagram**

Note: Some of the functional blocks, circuits, or constants in the block diagram may be omitted or simplified for explanatory purpose.

Note: All the grounding wires should be solid patterns and be externally terminated at only one point. Also, a grounding method should be considered for efficient heat dissipation. Careful attention should be paid to the layout of the output, VM and GND traces, to avoid short circuits across output pins or to the power supply or ground. If such a short circuit occurs, the device may be permanently damaged. Also, the utmost care should be taken for pattern designing and implementation of the device since it has power supply pins (VM, OUT\_A+, OUT\_A-, OUT\_B+, OUT\_B-, AGND, PGND, RSA and RSB) through which a particularly large current may run. If these pins are wired incorrectly, an operation error may occur or the device may be destroyed. The logic input pins must also be wired correctly. Otherwise, the device may be damaged owing to a current running through the IC that is larger than the specified current. Careful attention should be paid to design patterns and mounting.

**4. Pin Layout**



**Figure 4 Pin Layout Diagram**

## 5. Explanation of terminal function

table 5 Pin Description

No.	Pin name	function
1	AGC_OUT	Active Gain Control Reference Signal Output Terminal
2	TEST	Our test mode terminal (be sure to set it to L.) )
3	VM	VM Voltage Input Terminals
4	OUT_A+	Motor A-phase output terminal
5	RSA	Motor A-phase GND terminal
6	OUT_A-	Motor A-phase output terminal
7	OUT_B-	Motor B-phase output terminal
8	RSB	Motor B-phase GND terminal
9	OUT_B+	Motor B-phase output terminal
10	VM	VM Voltage Input Terminals
11	AGC_AUTO	Active Gain Control Automatic Time Setting Pin
12	ADMD	Mixed Decay/Auto Decay setting pin
13	AGC_ON	Active Gain Control setting pin
14	AWGS	Automatic Wave Generation System setting pin
15	PGND	Motor output GND terminal
16	AGND	GND pin
17	STOP_DET_VTH	Stall detection threshold setting pin Note: If you do not want to use stall detection, please open it.
18	OSCM	Resistor connection terminal for OSCM setting
19	KPKI_NANO	Continuous Micro-stepping Gain Setting Terminal Note: Connect to GND when not in use.
20	AGC_TIME	Active Gain Control Zero-Cross Position Identification Time Setting Terminal Note: When not in use, connect to GND.
21	FREQ_MIN	Active Gain Control OFF setting terminal at low speed Note: Connect to GND when not in use.
22	VSP_MIN	Active Gain Control attenuation setting pin Note: Connect to GND when not in use.
23	AGC_KI	Active Gain Control Control Gain Setting Pin Note: When not in use, connect to GND.
24	AGC_KP	Active Gain Control Control Gain Setting Pin Note: When not in use, connect to GND.
25	TARGET_ANGLE	Motor phase delay setting terminal Note: Connect to GND when not in use.
26	NFHYS	Hysteresis setting pin for NF detection Note: When not in use, connect to GND.
27	MTBLANK	tblank time setting terminal for motor M knot Note: Connect to GND when not in use.
28	STBLANK	tblank setting terminal for Slow Note: Connect to GND when not in use.
29	CTBLANK	tblank setting terminal for charge Note: When not in use, connect to GND.
30	VREG	5V Regulator pin
31	LO2	Status output terminal when an error is detected
32	LO1	Status output terminal when an error is detected
33	LO0	Status output terminal when an error is detected
34	MO	Electrical Angle Monitor Terminals
35	VREF	Reference power supply terminal for setting current value
36	SLEEP_X	SLEEP signal input terminal.
37	RESET_X	RESET signal input terminal. Initialize the electric horn.
38	CW_CCW	Rotation direction switching terminal
39	ENABLE	ENABLE signal input terminal. Controls the output ON/OFF of phase A and phase B.
40	CLK	Clock signal input terminal. The electric angle advances at the rising edge.
41	DMODE0	Excitation mode setting pin

42	DMODE1	Excitation mode setting pin
43	DMODE2	Excitation mode setting pin
44	DECAY1	Constant current chopping control selector terminal
45	DECAY2	Constant current chopping control selector terminal
46	PGND	Motor output GND terminal
47	SERIAL_CLK	CLK signal input for serial control
48	SERIAL_IN	Serial Control Signal Input/Output Terminals Note: In the case of $V_M < 5$ , control the signal input with a voltage less than or equal to $V_M$ .

## 6. Input/Output Equivalent Circuit

table 6 Input/output equivalent circuit

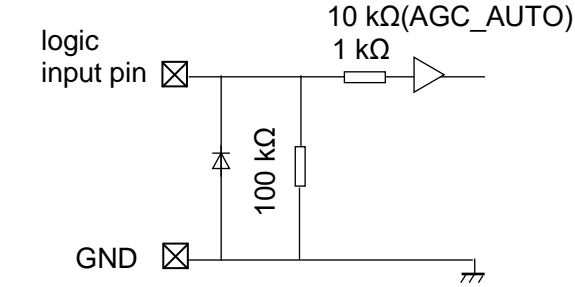
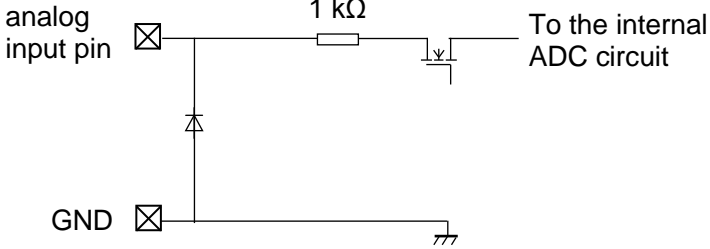
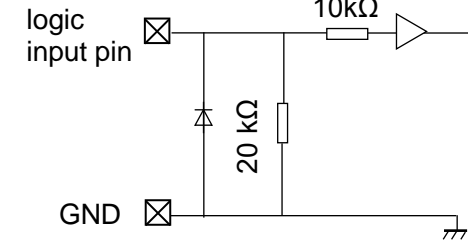
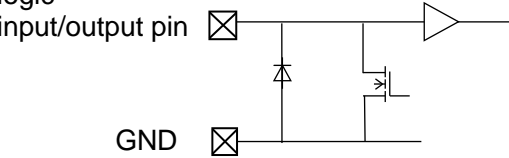
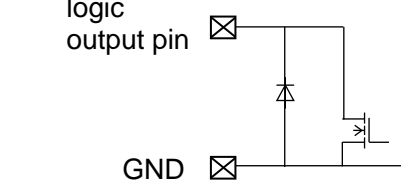
Pin name	Equivalent circuit
CLK ENABLE RESET_X CW/CCW DMODE0 DMODE1 DMODE2 SLEEP_X DECAY1 DECAY2 ADMD AGC_ON AGC_AUTO AWGS SERIAL_CLK	
CTBLANK STBLANK MTBLANK NFHYS TARGET_ANGLE KP KI VSP_MIN FREQ_MIN AGC_TIME KPKI_NANO	
TEST	
SERIAL_IN	
MO LO LO1 LO2	

<p>VREF</p>	
<p>OSCM</p>	
<p>AGC_OUT</p>	
<p>STOP_DET_VTH</p>	
<p>VM OUT_A+ OUT_A- OUT_B+ OUT_B- RSA RSB</p>	<p>Note: The same applies to OUT_B+ and OUT_B-.</p>

Note: The equivalent circuit diagrams may be simplified for explanatory purposes.

## 7. Operation description

### 7.1. Common Function Description: TB67S579FTG

#### 7.1.1. Function of the SLEEP\_X

By setting the device to sleep and then setting it to normal operation mode again, it is possible to wake up from the output forced OFF state due to the operation of the overtemperature detection circuit (TSD) and the overcurrent detection circuit (ISD). By setting SLEEP\_X = Low, the sleep mode is entered after 100 μs. After entering SLEEP\_X=High, normal operation is returned to 10 ms (maximum).

table 7.1.1 SLEEP\_X Function

SLEEP_X	Function
L	Sleep Mode (Charge Pump Stop, VCC Reg Stop)
H	Normal operation

#### 7.1.2. CLK Function

For each CLK, one electric angle advances. The signal is reflected at the Up edge.

table 7.1.2 CLK Function

CLK	Function
↑	Take the next step with UpEdge
↓	- (Preserve previous state)

#### 7.1.3. ENABLE Function

Switches the stepping motor drive ON/OFF. Normal constant current control is started by turning on the motor drive, and setting it to OFF turns off the MOSFET and the output is high impedance.

table 7.1.3 ENABLE Function

ENABLE	Function
H	Output MOSFET Operation: ON (Normal Operation)
L	Output MOSFET operation: OFF (operation stopped, high impedance)

#### 7.1.4. CW\_CCW Function

Switch the direction of rotation of the stepper motor.

table 7.1.4 CW\_CCW Function

CW_CCW	Function
H	Forward Rotation (CW)
L	Reversal (CCW)

## 7.1.5. RESET\_X Function

The internal electrical horn can be initialized.

table 7.1.5.1 RESET\_X Function

RESET_X	Function
H	Normal operation
L	Electric Angular Initialization

The current of each phase when RESET is applied is as follows. (e.g. in microstepping operation)

table 7.1.5.2 Phase current at RESET

Excitation mode	Phase A current	Phase B current	Initial Electric Angle
Full Step	100%	100%	45°
Half Step (A)	100%	100%	45°
Half Step (b)	71%	71%	45°
1 / 4 Step	71%	71%	45°
1 / 8 Step	71%	71%	45°
1 / 16 Step	71%	71%	45°
1 / 32 Step	71%	71%	45°

Note: When using AWGS and Continuous Micro-stepping, each phase is fixed at 71% at RESET.

The above table is for normal  $\mu$ Step. Even if the mode is switched during RESET, the current value changes in sync with the control signal.

## 7.1.6. DMODE0, DMODE1, and DMODE2 Function

Switch the step resolution.

table 7.1.6 DMODE Function

DMODE0	DMODE1	DMODE2	Function
L	L	L	Full Step
L	L	H	Half Step (A)
L	H	L	Half Step (b)
L	H	H	1 / 4 Step
H	L	L	1 / 8 Step
H	L	H	1 / 16 Step
H	H	L	1 / 32 Step
H	H	H	1 / 32 Step

## 7.1.7. Sequence by drive mode in clock input control mode

[Full step setting]

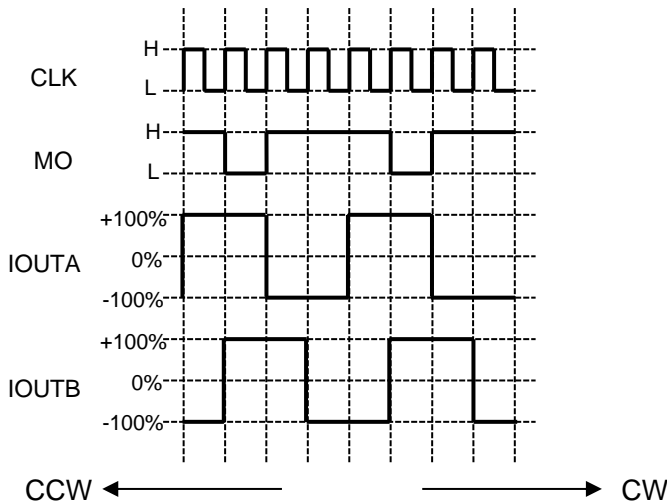

Figure 7.1.7.1 Full step setting

[Half step (a) setting]

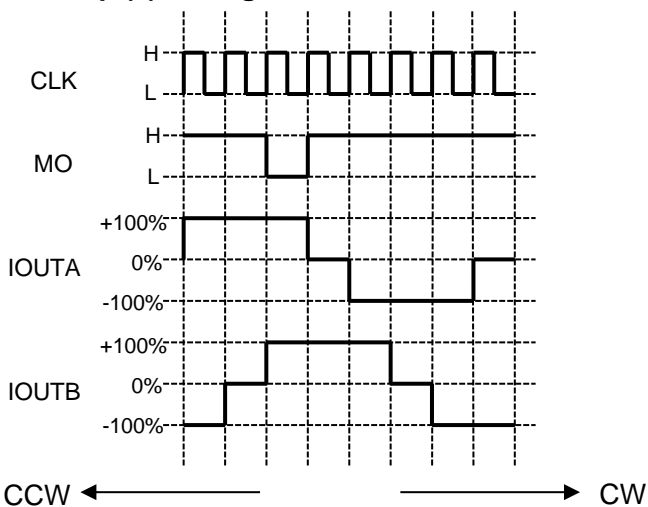

Figure 7.1.7.2 Half step (A) setting

Note : MO output is the terminal waveform in Pull Up state.

Note : The timing chart is simplified to explain the function and operation.

[Half step (b) setting]

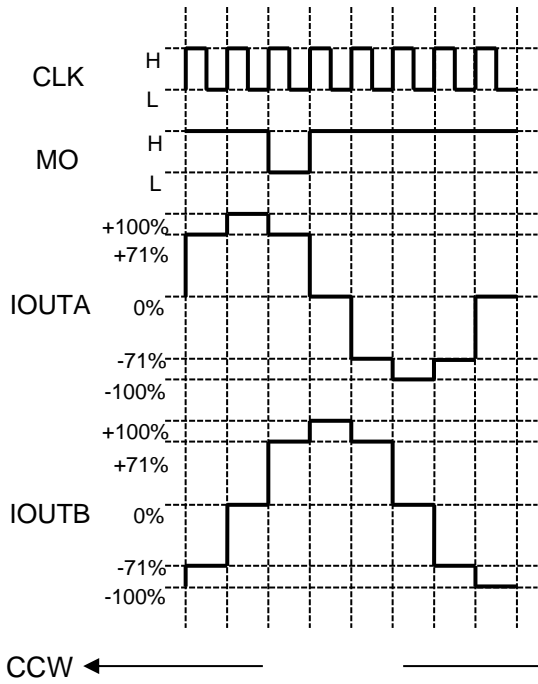

Figure 7.1.7.3 Half step (b) setting

[1 / 4 step setting]

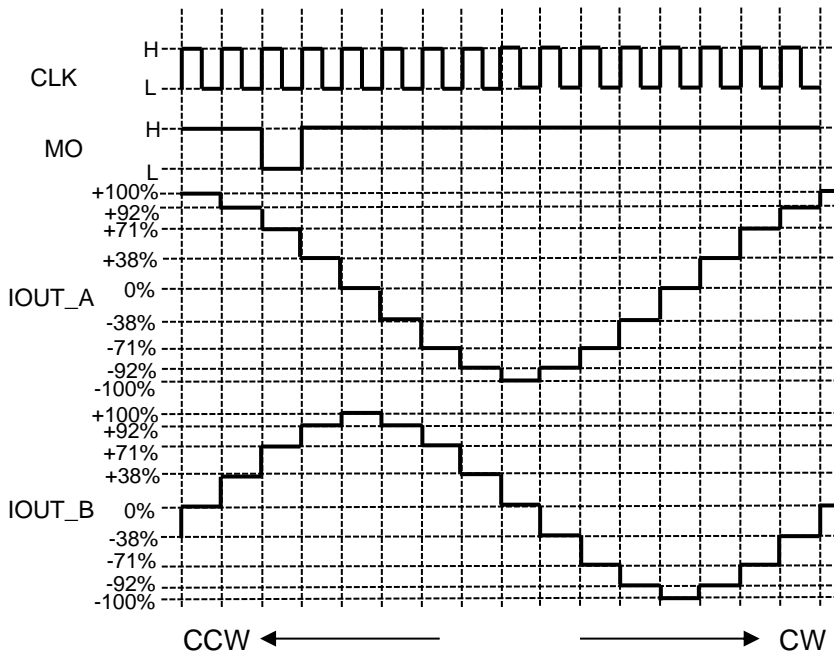

Figure 7.1.7.4 1 / 4 step setting

Note : MO output is the terminal waveform in Pull Up state.  
 Note : The timing chart is simplified to explain the function and operation.

[1 / 8 step setting]

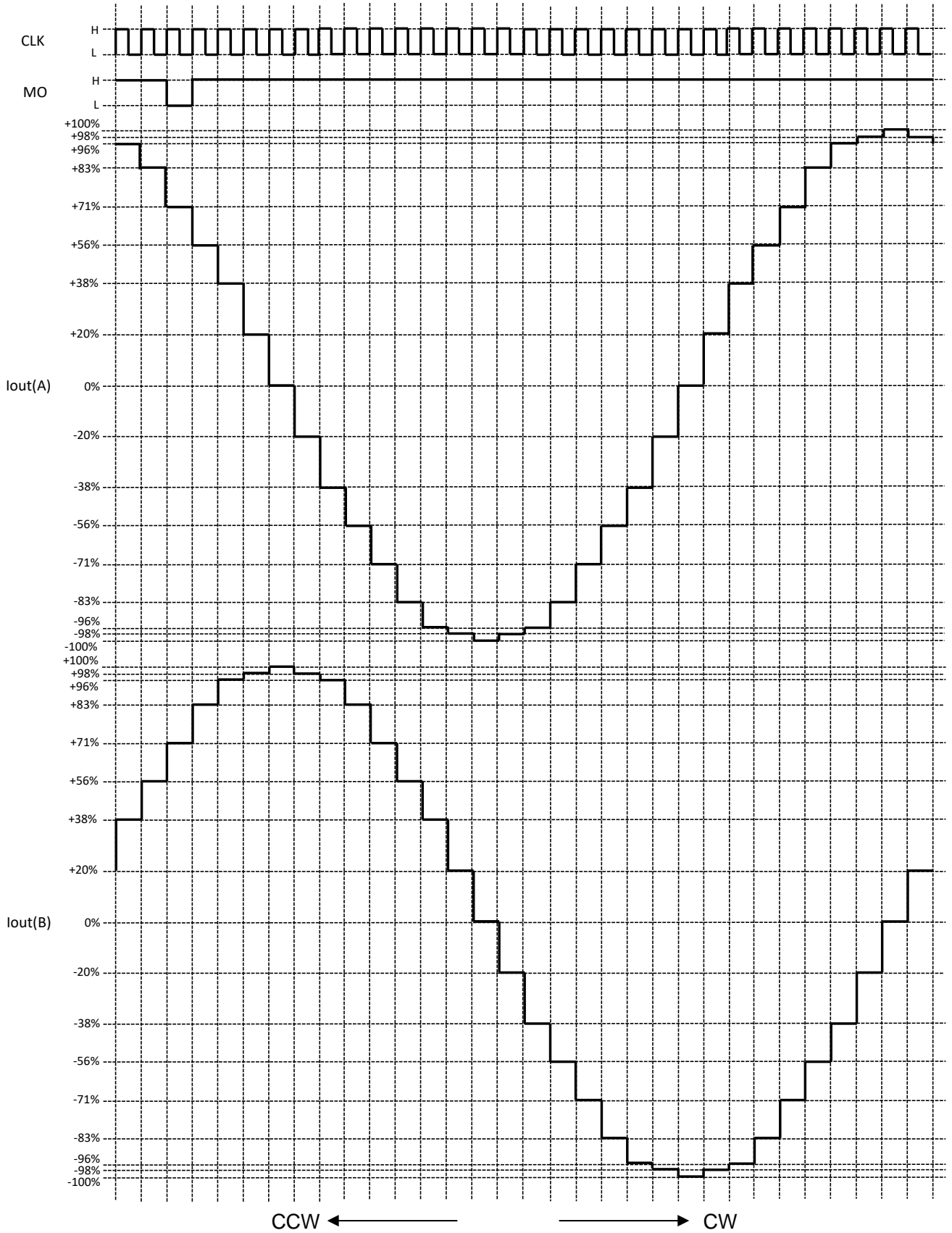

Figure 7.1.7.5 1 / 8 step setting

Note : MO output is the terminal waveform in Pull Up state.

Note : The timing chart is simplified to explain the function and operation

## [1 / 16 step setting]

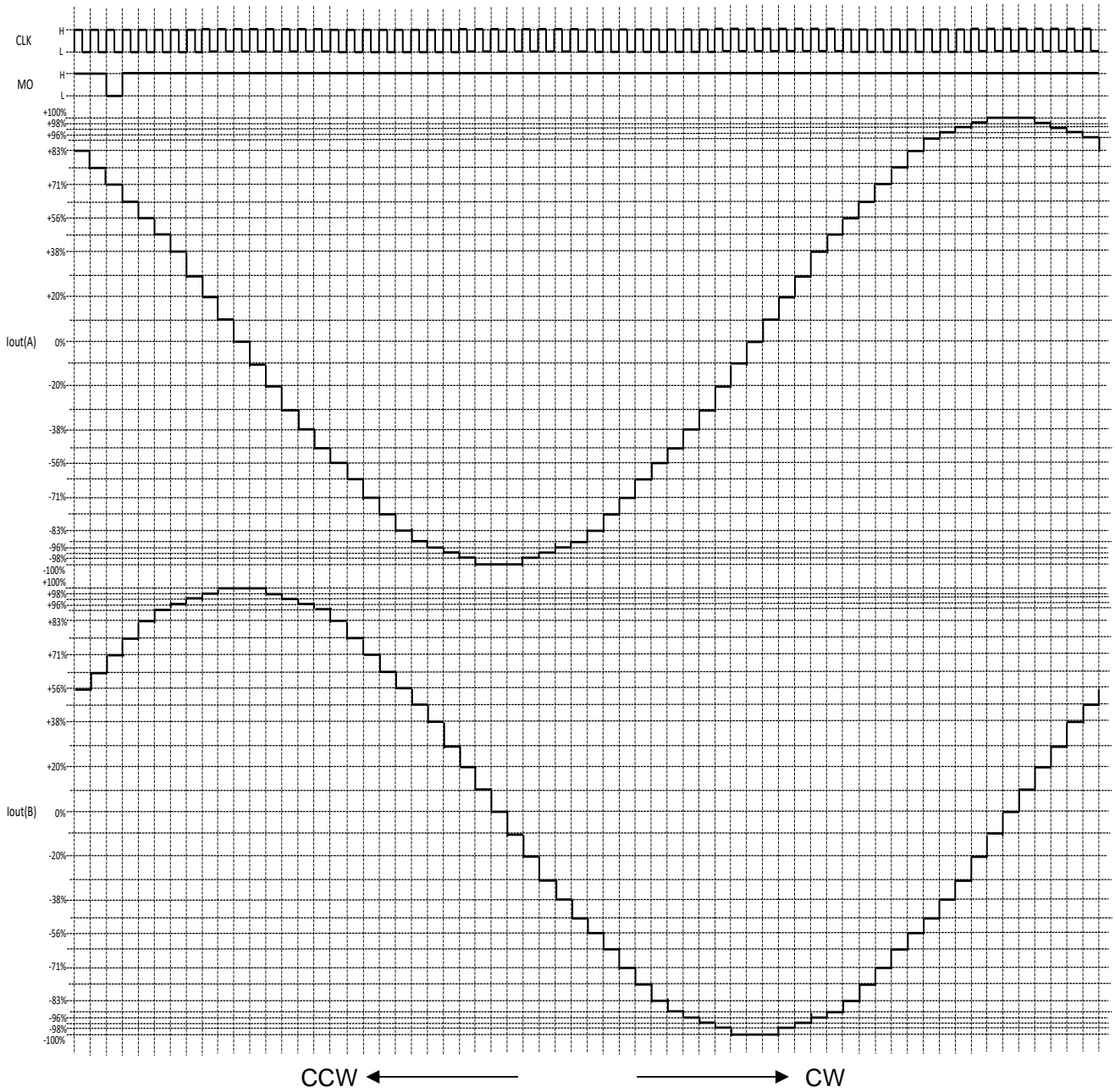
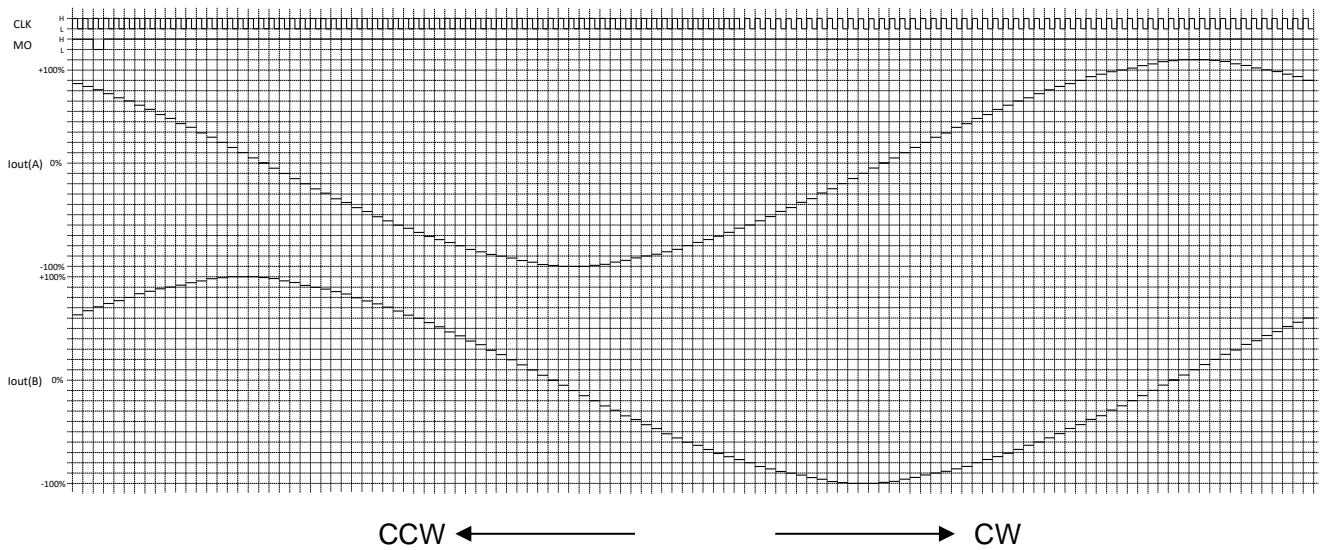

Figure 7.1.7.6 1 / 16 step Setting

Note : MO output is the terminal waveform in Pull Up state.  
Note : The timing chart is simplified to explain the function and operation

[1 / 32 step setting]



**Figure 7.1.7.7 1 / 32 step Setting**

Note : MO output is the terminal waveform in Pull Up state.  
 Note : The timing chart is simplified to explain the function and operation

### 7.1.8. Excitation Method and Set Current Value

Please refer to the table below for the Step current for each excitation. The table shows the case where CW\_CCW = H setting.

table 7.1.6 Excitation Method and Set Current Value

STEP	AWGS (1/32)		1/32		1/16		1/8		1/4		1/2(b)		1/2(a)		Full	
	Ach (%)	Bch (%)	Ach (%)	Bch (%)	Ach (%)	Bch (%)	Ach (%)	Bch (%)	Ach (%)	Bch (%)	Ach (%)	Bch (%)	Ach (%)	Bch (%)	Ach (%)	Bch (%)
00	100	0	100	0	100	0	100	0	100	0	100	0	100	0		
01	100	2														
02	100	5	100	5												
03	100	7														
04	100	10	100	10	100	10										
05	99	12														
06	99	15	99	15												
07	99	17														
08	98	20	98	20	98	20	98	20								
09	98	22														
010	97	24	97	24												
011	96	27														
012	96	29	96	29	96	29										
013	95	31														
014	94	34	94	34												
015	93	36														
016	92	38	92	38	92	38	92	38	92	38						
017	91	41														
018	90	43	90	43												
019	89	45														
020	88	47	88	47	88	47										
021	87	49														
022	86	51	86	51												
023	84	53														
024	83	56	83	56	83	56	83	56								
025	82	58														
026	80	60	80	60												
027	79	62														
028	77	63	77	63	77	63										
029	76	65														
030	74	67	74	67												

STEP	AWGS (1/32)		1/32		1/16		1/8		1/4		1/2(b)		1/2(a)		Full		
	Ach (%)	Bch (%)	Ach (%)	Bch (%)	Ach (%)	Bch (%)	Ach (%)	Bch (%)	Ach (%)	Bch (%)	Ach (%)	Bch (%)	Ach (%)	Bch (%)	Ach (%)	Bch (%)	
031	72	69															
032	71	71	71	71	71	71	71	71	71	71	71	71	71	100	100	100	100
033	69	72															
034	67	74	67	74													
035	65	76															
036	63	77	63	77	63	77											
037	62	79															
038	60	80	60	80													
039	58	82															
040	56	83	56	83	56	83	56	83									
041	53	84															
042	51	86	51	86													
043	49	87															
044	47	88	47	88	47	88											
045	45	89															
046	43	90	43	90													
047	41	91															
048	38	92	38	92	38	92	38	92	38	92							
049	36	93															
050	34	94	34	94													
051	31	95															
052	29	96	29	96	29	96											
053	27	96															
054	24	97	24	97													
055	22	98															
056	20	98	20	98	20	98	20	98									
057	17	99															
058	15	99	15	99													
059	12	99															
060	10	100	10	100	10	100											
061	7	100															
062	5	100	5	100													
063	2	100															
064	0	100	0	100	0	100	0	100	0	100	0	100	0	100			
065	-2	100															
066	-5	100	-5	100													

STEP	AWGS (1/32)		1/32		1/16		1/8		1/4		1/2(b)		1/2(a)		Full	
	Ach (%)	Bch (%)	Ach (%)	Bch (%)	Ach (%)	Bch (%)	Ach (%)	Bch (%)	Ach (%)	Bch (%)	Ach (%)	Bch (%)	Ach (%)	Bch (%)	Ach (%)	Bch (%)
067	-7	100														
068	-10	100	-10	100	-10	100										
069	-12	99														
070	-15	99	-15	99												
071	-17	99														
072	-20	98	-20	98	-20	98	-20	98								
073	-22	98														
074	-24	97	-24	97												
075	-27	96														
076	-29	96	-29	96	-29	96										
077	-31	95														
078	-34	94	-34	94												
079	-36	93														
080	-38	92	-38	92	-38	92	-38	92	-38	92						
081	-41	91														
082	-43	90	-43	90												
083	-45	89														
084	-47	88	-47	88	-47	88										
085	-49	87														
086	-51	86	-51	86												
087	-53	84														
088	-56	83	-56	83	-56	83	-56	83								
089	-58	82														
090	-60	80	-60	80												
091	-62	79														
092	-63	77	-63	77	-63	77										
093	-65	76														
094	-67	74	-67	74												
095	-69	72														
096	-71	71	-71	71	-71	71	-71	71	-71	71	-71	71	-100	100	-100	100
097	-72	69														
098	-74	67	-74	67												
099	-76	65														
0100	-77	63	-77	63	-77	63										
0101	-79	62														
0102	-80	60	-80	60												

STEP	AWGS (1/32)		1/32		1/16		1/8		1/4		1/2(b)		1/2(a)		Full	
	Ach (%)	Bch (%)	Ach (%)	Bch (%)	Ach (%)	Bch (%)	Ach (%)	Bch (%)	Ach (%)	Bch (%)	Ach (%)	Bch (%)	Ach (%)	Bch (%)	Ach (%)	Bch (%)
—																
θ103	-82	58														
θ104	-83	56	-83	56	-83	56	-83	56								
θ105	-84	53														
θ106	-86	51	-86	51												
θ107	-87	49														
θ108	-88	47	-88	47	-88	47										
θ109	-89	45														
θ110	-90	43	-90	43												
θ111	-91	41														
θ112	-92	38	-92	38	-92	38	-92	38	-92	38						
θ113	-93	36														
θ114	-94	34	-94	34												
θ115	-95	31														
θ116	-96	29	-96	29	-96	29										
θ117	-96	27														
θ118	-97	24	-97	24												
θ119	-98	22														
θ120	-98	20	-98	20	-98	20	-98	20								
θ121	-99	17														
θ122	-99	15	-99	15												
θ123	-99	12														
θ124	-100	10	-100	10	-100	10										
θ125	-100	7														
θ126	-100	5	-100	5												
θ127	-100	2														
θ128	-100	0	-100	0	-100	0	-100	0	-100	0	-100	0	-100	0		

## 7.1.9. Selectable Mixed Decay Function

Selectable Mixed Decay is a function that allows the amount of current regeneration during the current regeneration period to be adjusted by terminals.

Mixed decay control itself is achieved by switching between three controls: Charge, Slow, and Fast. The DECAY pin allows this constant current control to be selected from four settings. This pin function is enabled when the ADMD pin = L. If this setting is switched during constant current operation, the setting after switching will be reflected from the next chopping cycle. This function is disabled when Active gain control and Continuous Micro-stepping are selected. When Active gain control and Continuous Micro-stepping are set, the sequence is basically Charge ⇒ Slow, and Fast is turned on only when forced discharge is required.

table 7.1.9 Selectable Mixed Decay Function

DECAY2	DECAY1	Function
L	L	Mixed Decay
L	H	Slow Decay only
H	L	Fast Decay only
H	H	Advanced Dynamic Mixed Decay

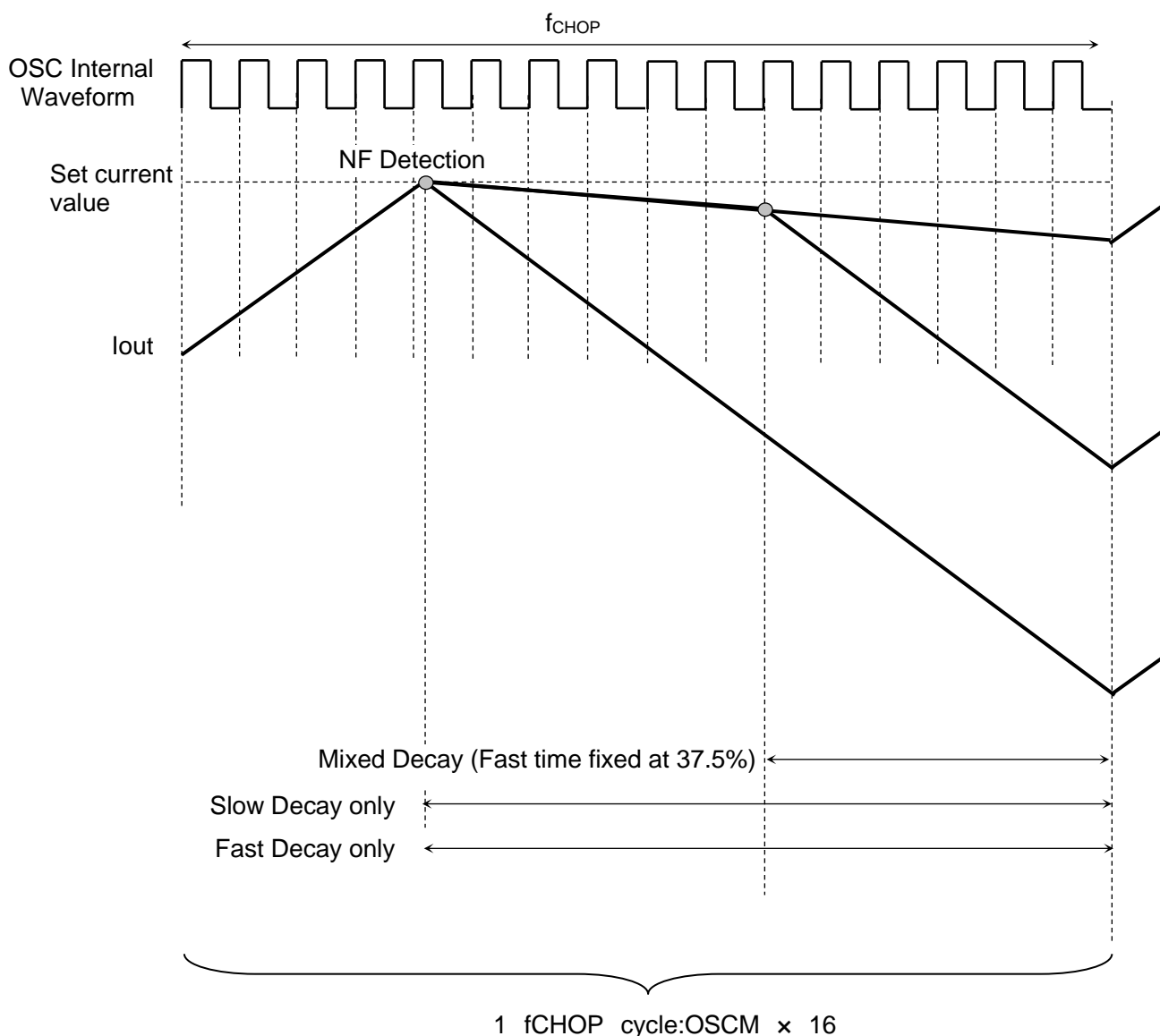
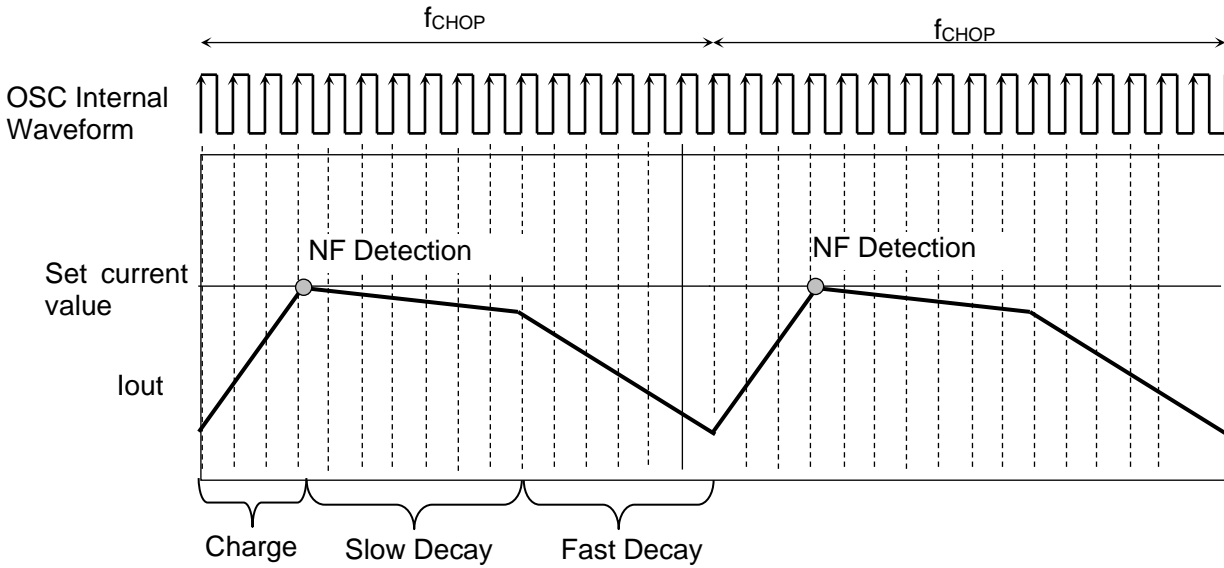

Figure 7.1.9 Current waveform for each decay setting

Note: Timing charts may be simplified for explanatory purpose.

### 7.1.9.1. Mixed Decay Waveform (Current Waveform)



**Figure 7.1.9.1 Mixed Decay Waveform**

Note: Timing charts may be simplified for explanatory purpose.

### 7.1.9.2. Constant Current PWM Operation Time

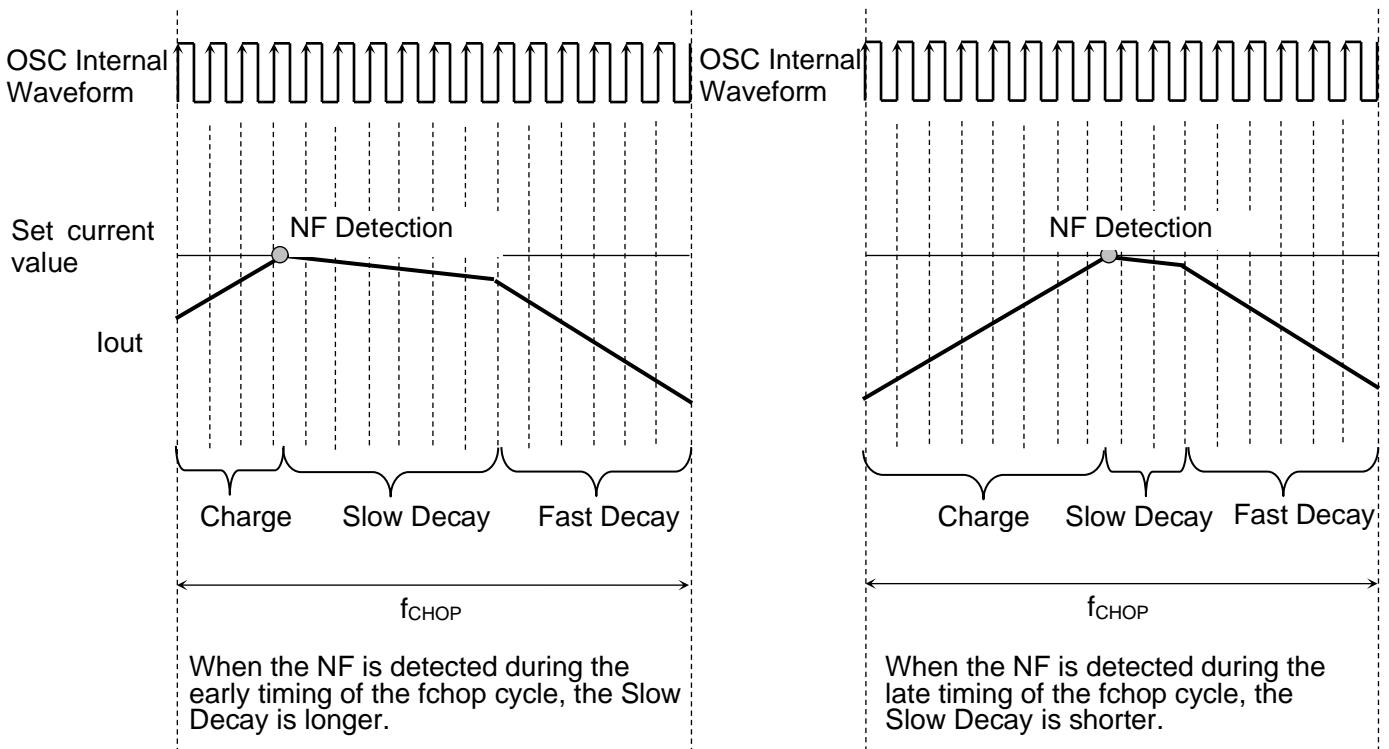

**Figure 7.1.9.2.1 Constant Current PWM Operation Time**

The Charge period (the time until the motor current reaches the set current value) is determined by the operating status. Therefore the NF detection (the motor current reaches the set current value) timing within the chopping cycle will change. When the NF is detected during the early timing of the  $f_{chop}$  cycle, the Slow Decay is longer. When the NF is detected during the late timing of the  $f_{chop}$  cycle, the Slow Decay is shorter, as shown above.

Note: The chopping cycle is determined as:  $f_{chop} - (\text{Charge} + \text{Fast Decay}) = \text{Slow Decay}$   
 (Fast Decay time is 37.5% fixed (OSCM: 6 clocks))

Note: Timing charts may be simplified for explanatory purpose.

## Mixed Decay Current Waveform

- When the set current value is in the direction of increasing

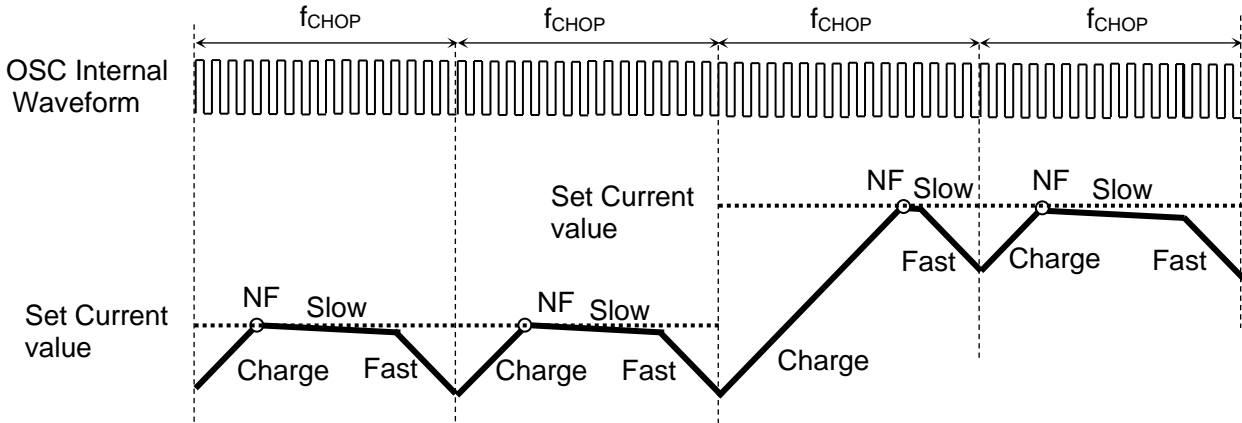

Figure 7.1.9.2.2 When the set current value is in the direction of increasing

- When the charge period is more than 1 f<sub>CHOP</sub> cycle

When the Charge period (the motor current reaches next step of the set current value) is longer than 1 f<sub>chop</sub> cycle, the Charge period extends until the motor current reaches the NF threshold. Once the current reaches the next current step, then the sequence goes on to Mixed Decay control.

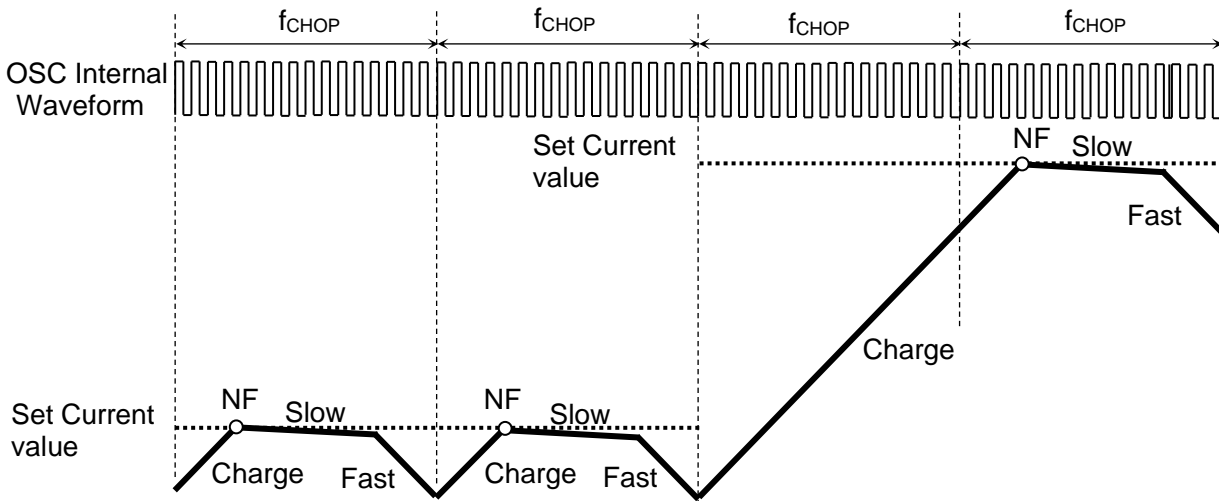

Figure 7.1.9.2.3 When the charge period is more than 1 f<sub>CHOP</sub> cycle

- When the set current value is in the direction of decreasing

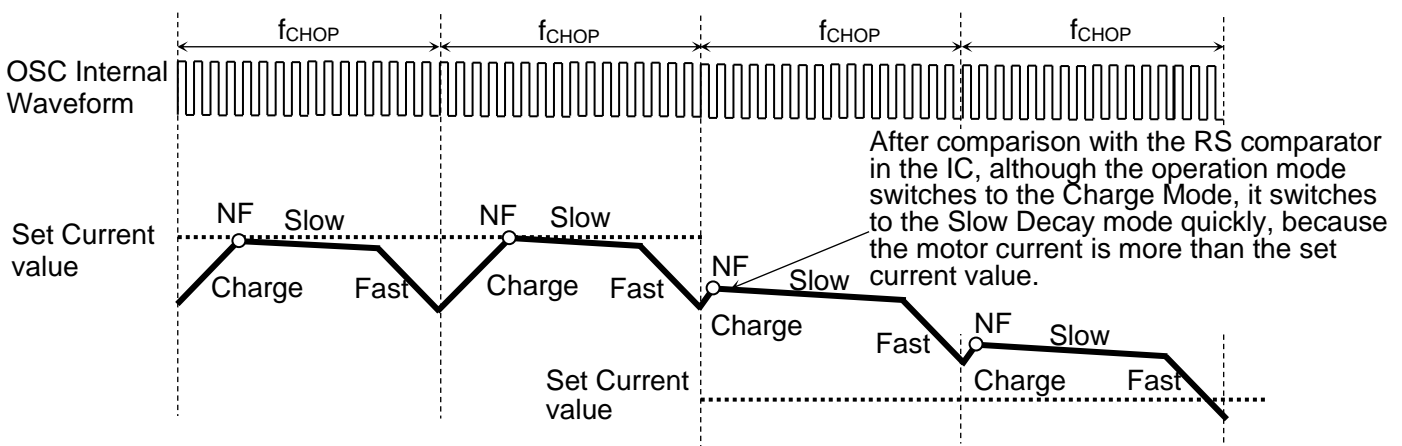

Figure 7.1.9.2.4 When the set current value is in the direction of decreasing

Note: Timing charts may be simplified for explanatory purpose.

### 7.1.9.3. Advanced Dynamic Mixed Decay Constant Current Control

The Advanced Dynamic Mixed Decay monitors both the current which flows from the power supply to the motor, and the current which regenerates from the motor to the power supply. The Advanced Dynamic Mixed Decay also controls constant current PWM.

The basic sequence of the Advanced Dynamic Mixed Decay is as follows.

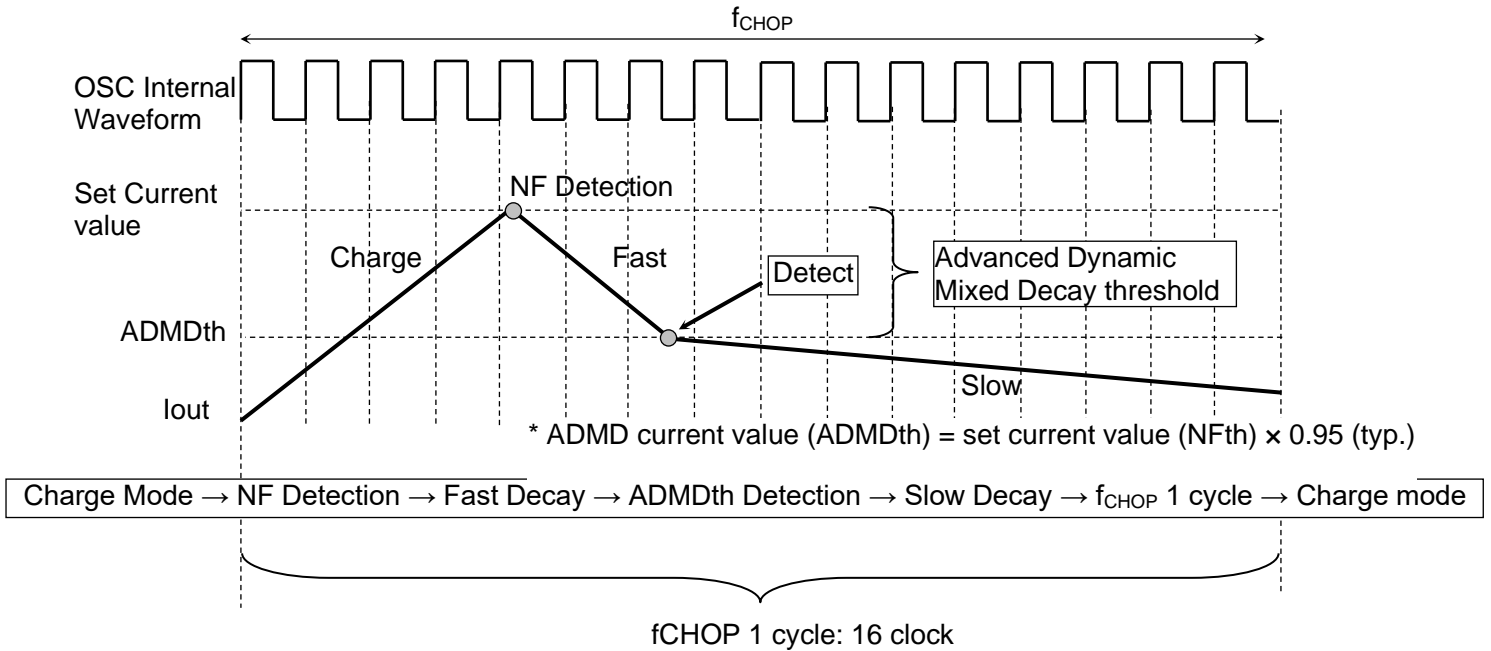

**Figure 7.1.9.3.1 Advanced Dynamic Mixed Decay Constant Current Control**

Note: Timing charts may be simplified for explanatory purpose.

Note: The values in the timing chart are reference values.

Each filter is attached in order to avoid current-detection error caused by the external noise, etc. (Shown in below figure.)

L value of the motor to be used is small, and when the current value reaches ADMDth (ADMD current value) within the ADMDtblank period, it changes to Slow operation after progress during the ADMDtblank. In this case, the ADMD current value (ADMDth) becomes smaller than "the set current value (NFth) x 0.95 (typ.)".

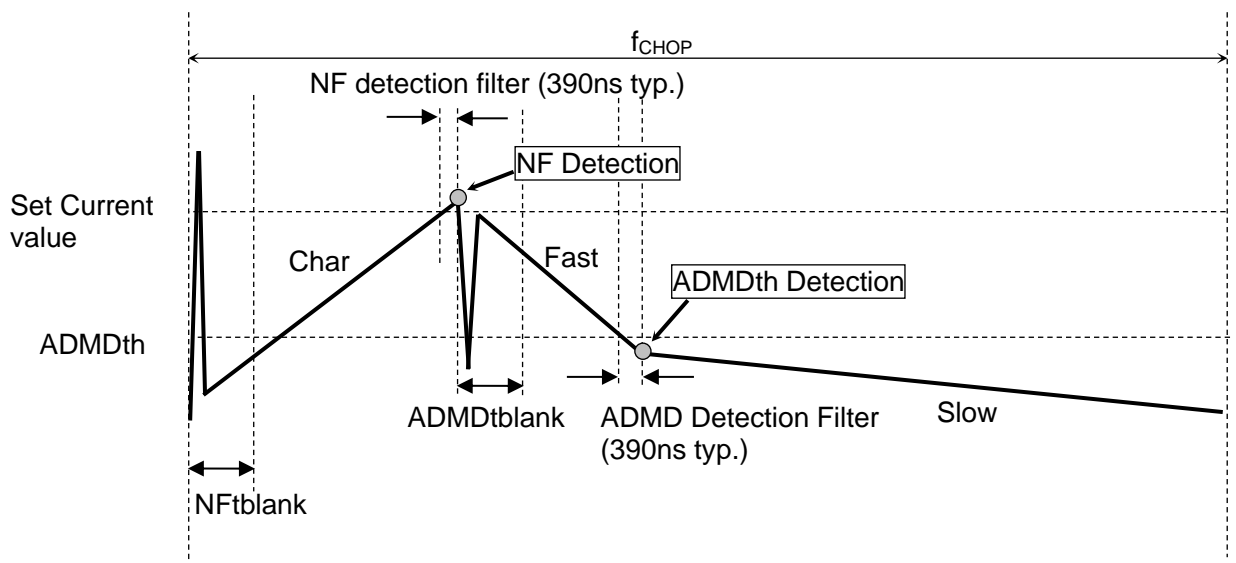

**Figure 7.1.9.3.2 Advanced Dynamic Mixed Decay Constant Current Control**

Note: Each tblank time is set in the CTBLANK setting, etc.

Note: Timing charts may be simplified for explanatory purpose.

Note: The values in the timing chart are reference values.

**7.1.9.4. Advanced Dynamic Mixed Decay Current Waveform**

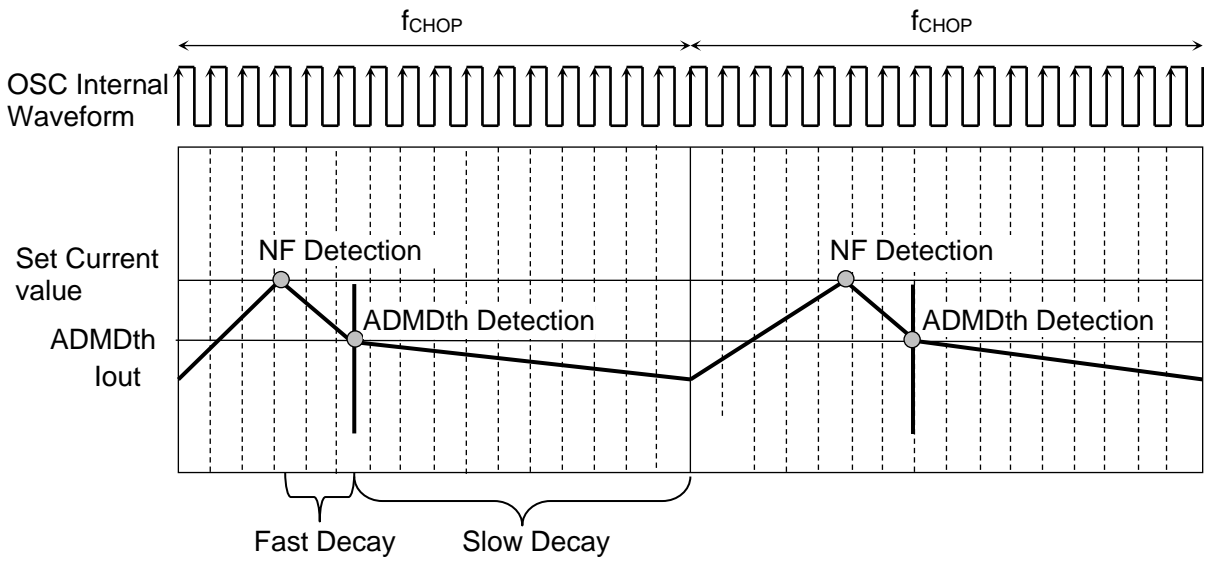

**Figure 7.1.9.4 Advanced Dynamic Mixed Decay Current Waveform**

Note: Timing charts may be simplified for explanatory purpose.

## 7.1.9.5. ADMD Current Waveform

- When the set current value is in the direction of increasing

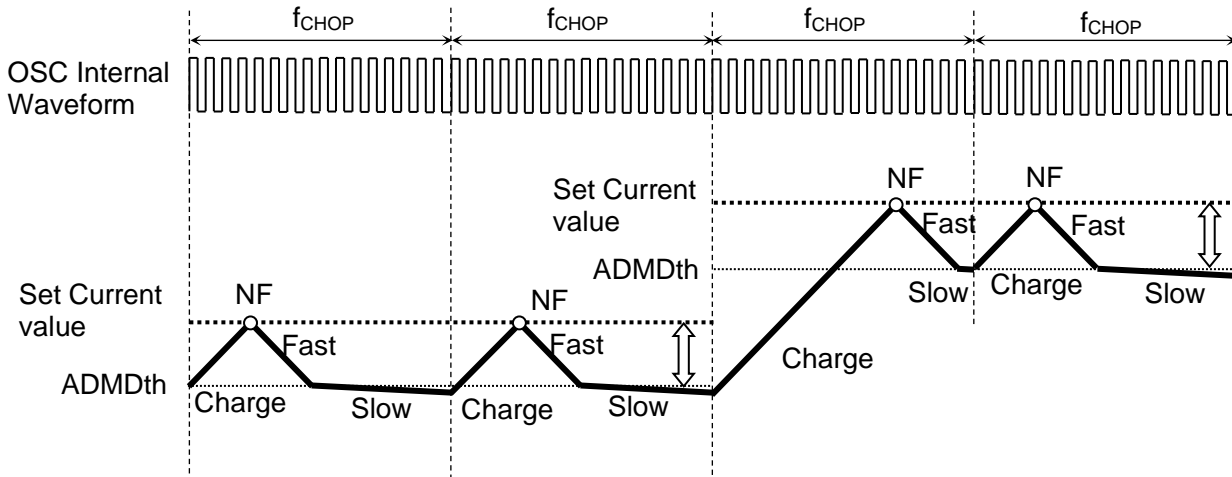

Figure 7.1.9.5.1 When the set current value is in the direction of increasing

- When Charge period  $\geq 1$  fchop cycle

When the period until the motor current value reaches the next setting value (Charge period) such as switching of the set current value, exceeds the setting 1 chopping cycle ( $f_{chop}$ ), the Charge mode continues in the next  $f_{chop}$  cycle. The operation mode moves to the Advanced Dynamic Mixed Decay control after the motor current value reaches the NF.

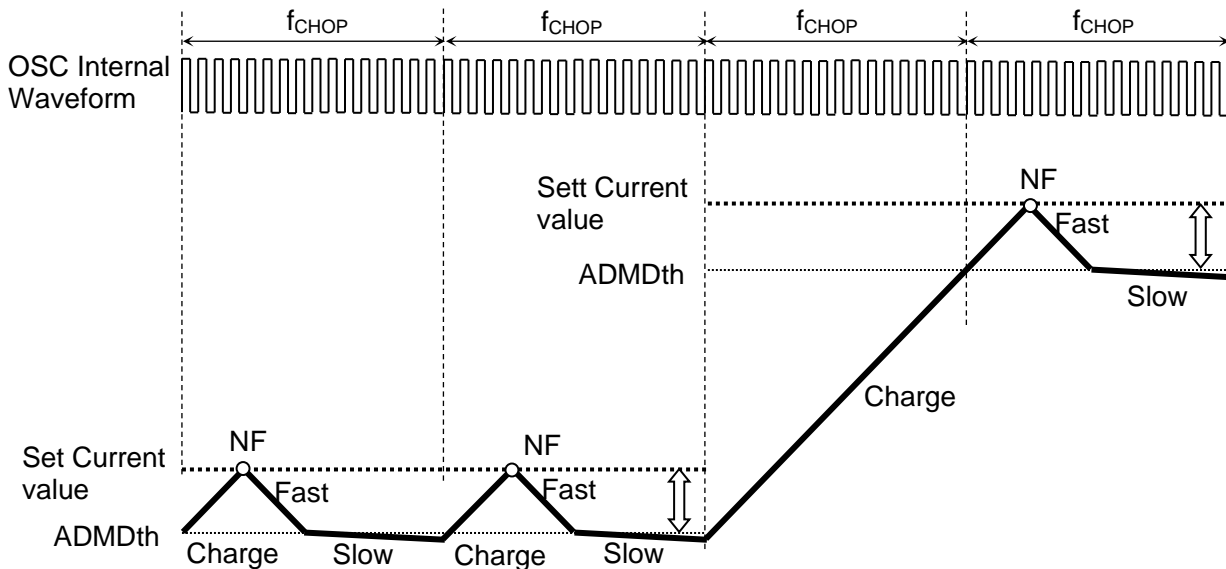

Figure 7.1.9.5.2 When Charge period  $\geq 1$  fchop cycle

Note: Timing charts may be simplified for explanatory purpose.

- When the next current step is lower:

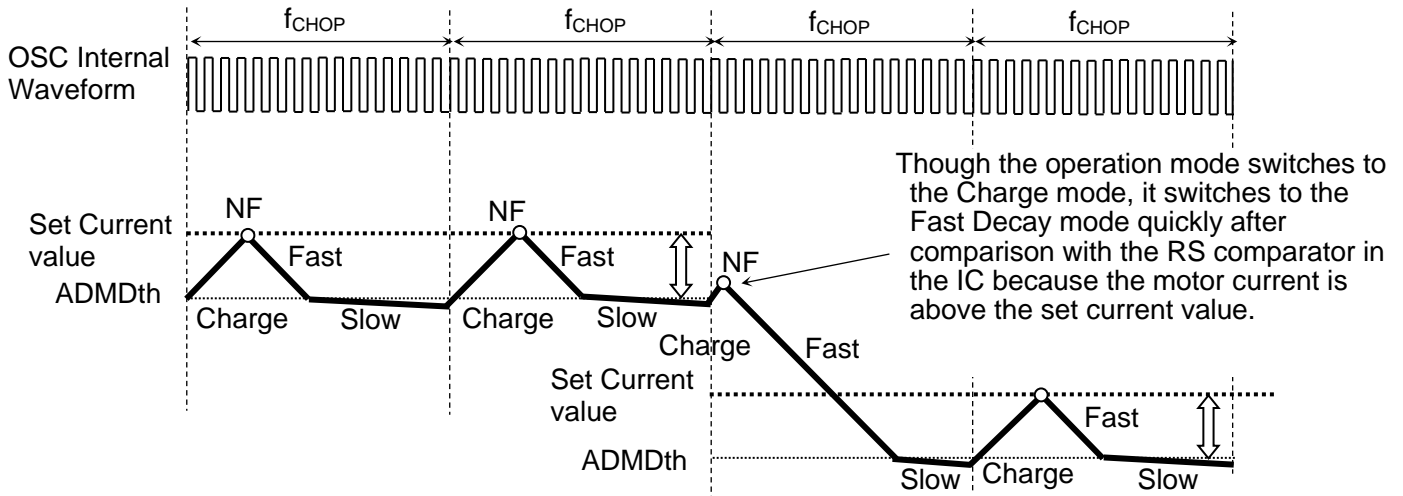

Figure 7.1.9.5.3 When the next current step is lower

- Fast period > 1  $f_{chop}$  cycle  
(The motor current does not reach the ADMD threshold during 1  $f_{chop}$  cycle.)

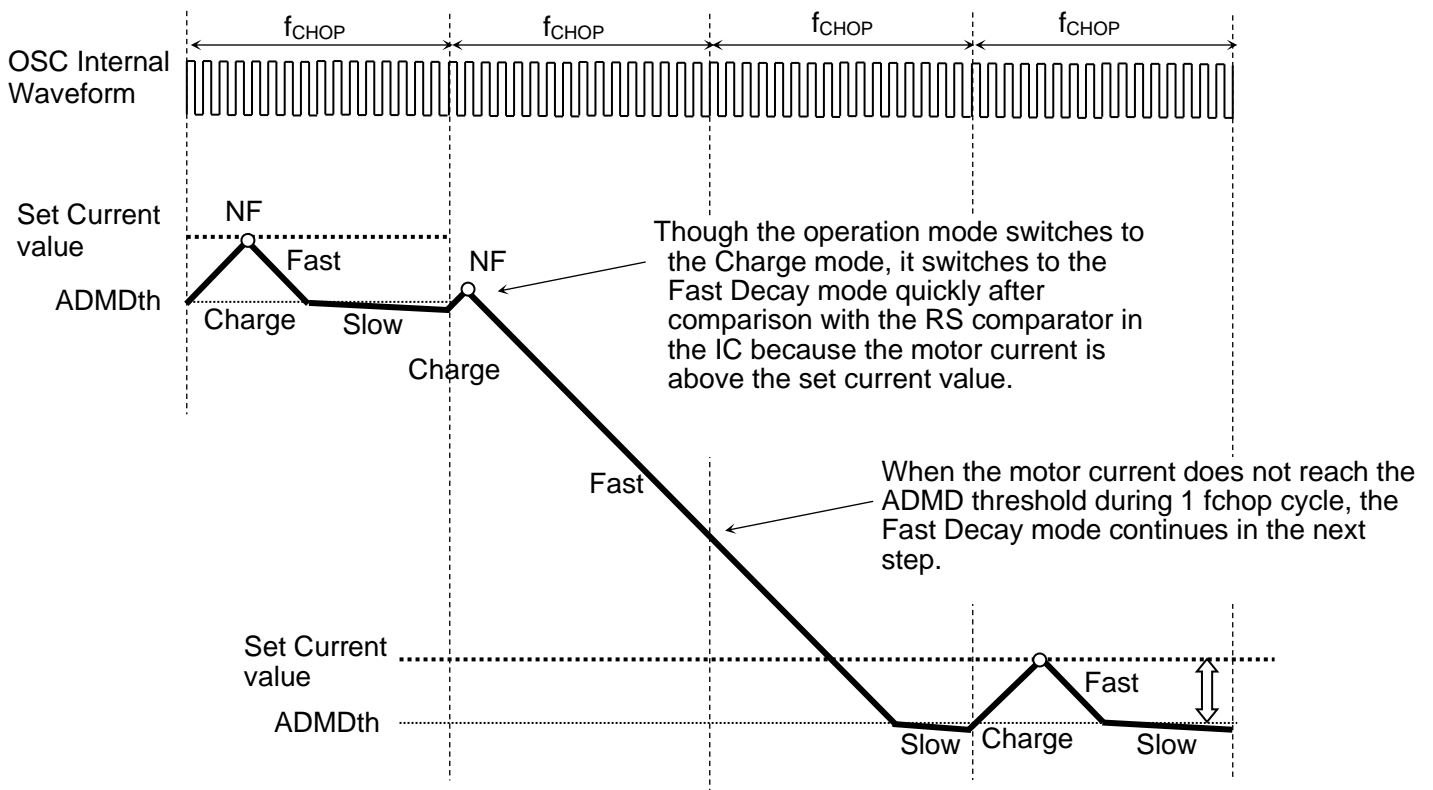

Figure 7.1.9.5.4 Fast period > 1  $f_{chop}$  cycle

Note: Timing charts may be simplified for explanatory purpose.

## 7.1.9.6. ADMD pin Function

You can switch between Mixed Decay and Auto Decay. When Mixed Decay is selected, Decay can be set using the DECAY1/2 pins. When Auto Decay is selected, the constant current control of Charge-Slow-Charge (Fast) is used. When this function is activated when Active gain control is selected, be sure to set ADMD=L, Continuous Micro-stepping is selected, be sure to set ADMD=H. If the ADMD pin is switched during chopping operation, the setting will be switched at the next charge timing.

table 7.1.9.6 ADMD pin Function

ADMD	Function
L	Mix Decay mode (switching is enabled by the DECAY1/2 pin)
H	Auto Decay Mode (Charge⇒Slow⇒Charge (Fast) ··· )

## 7.1.9.7. MO Function

You can check the electrical angle inside. Connect the output of the MO pin to a potential of 3.3 V or 5 V with a pull-up resistor of 10 k ~ 100 kΩ.

table 7.1.9.7 MO Function

MO	Function
H (during pull-up)	The electric angle is other than the initial value.
L	The electric angle is the initial value.

## 7.1.10. LO (Error Detection Flag Output) function

The LO function is a function that outputs an external signal when the error detection function is activated. To restore the LO pin, the VM power is turned back on or the SLEEP pin is used to restore normal operation. (When in TSD auto-recovery mode, it is synchronized to TSD.)

Since it is an open-drain terminal, when using the function, the outputs of the LO0, LO1, and LO2 terminals should be connected to a potential of 3.3 V or 5 V with a pull-up resistor of 10 kΩ ~ 100 kΩ. Normally, the LO0 pin level is Hi-Z (the internal MOSFET is OFF). When an error detection function (over-temperature (TSD), over-current (ISD), etc.) is activated, the pin level is set to L (internal MOSFET is turned on). If the error detection is canceled by re-cycling the VM power cycle or sleep mode, the LO pin will return to the "normal state (normal operation)" again. If the LO pin is not used, set the pin to open. In addition, it is possible to identify the detected error condition by checking the LO1 and 2 pin states. If multiple errors are detected at the same time, the one with the highest priority is prioritized and output. (Error priority: ISD>TSD>OPD>STD)

table 7.1.10 LO Function

LO0	LO1	LO2	Function	
H (during pull-up)	H (during pull-up)	H (during pull-up)	Normal (Normal Operation)	Priority: High
L	H (during pull-up)	H (during pull-up)	ISD (Motor Power Stop)	
L	H (during pull-up)	L	TSD (Motor Output Stop)	
L	L	H (during pull-up)	Output open (motor output operation continued)	Priority: Small
L	L	L	Stall (motor output operation continued)	

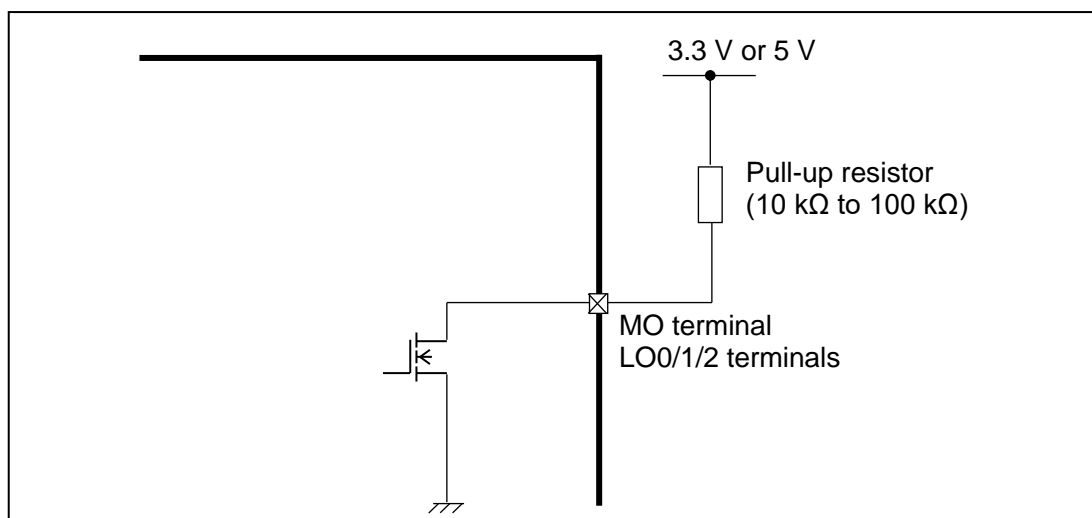

Figure 7.1.10 LO Function

Note: Equivalent circuits may be omitted or simplified in order to explain the circuit.

## 7.1.11. Output Open Detection Function

When the motor output is Open, it is a function that detects it as an error.

Even when a motor is connected, when the difference between the set current set by VREF and the actual current is large (when VREF is large and at high rpm), or when the required rotation speed is high for VREF, where the current fluctuation in one electric angle is less than a certain level (at high rotation when Vref is small). Error detection also works. Therefore, please evaluate carefully before setting VREF when using it.

## 7.2. Automatic Wave Generation System (AWGS) function

AWGS is a function that realizes a pseudo-sine wave even with the input CLK of Full step. In a normal  $\mu$ Step, if the rotational speed is to be maintained at the same rate as during Full step, the CLK frequency must be increased according to the number of steps. By using this function, the TB67S579FTG automatically completes the input CLK, so that  $\mu$ Step operation is possible even with the same CLK as the two-phase excitation. AWGS can be switched from any  $\mu$ Step state. When AWGS is selected, the 1/32 Step operation is forced.

table 7.2 Automatic Wave Generation System (AWGS) function

AWGS	Function
L	Normal $\mu$ Step operation
H	Automatic Wave Generation System (AWGS) operation (1/32 Step)

Note: AWGS operation requires 2 clk spare clks. After the Mode setting is set to Full step, 2CLK works with Full step, after AWGS is set.

### [Normal $\mu$ Step ( Full Step )]

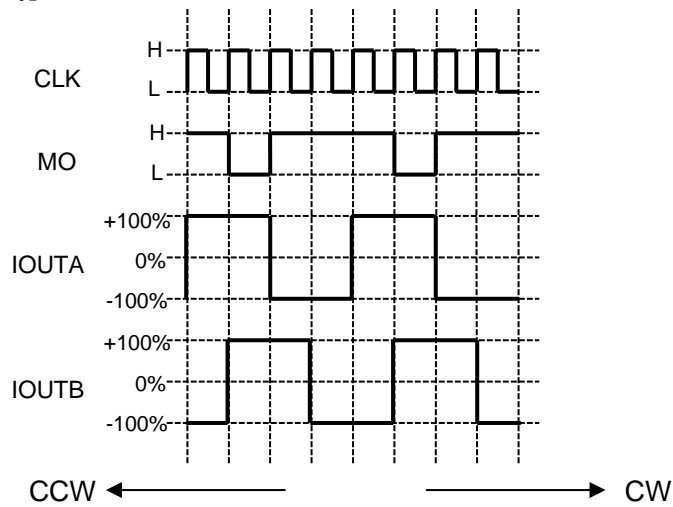

Figure 7.2.1 Normal  $\mu$ Step ( Full Step )

### [AWGS (1/32): Full step mode]

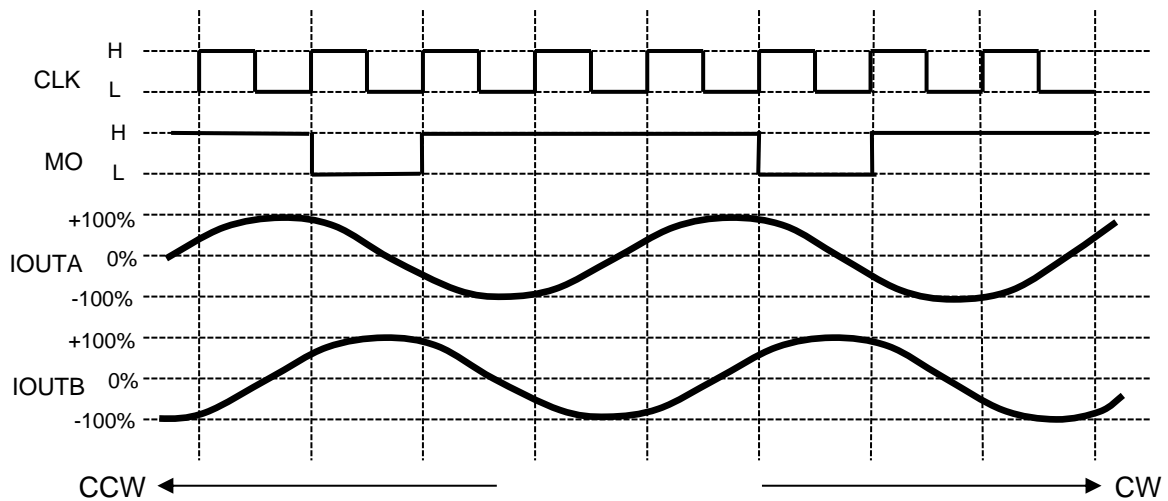

Figure 7.2.2 AWGS ( Full step mode )

Note: The MO output is the terminal waveform in the pull up state. The width of the MO at AWGS is output as a width synchronized to the external CLK, similar to the  $\mu$ Step mode.

Note: Timing charts may be simplified for explanatory purpose.

### 7.3. Active gain control function

#### 7.3.1. Active gain control configuration function

The AGC\_ON pin allows the active gain control function to be switched on and off. In the case of H, it is ON, and in the case of L, it is OFF. When the active gain control is ON, the TB67S579FTG gradually reduces the motor current according to the load torque, up to the current set by the VREF pin. The lower limit of the attenuation current is the current value set at the VSP\_MIN pin. When the active gain control is OFF, the motor current is the current value set by the VREF pin.

**table 7.3.1 Active gain control configuration function**

AGC_ON pin input	Function
L	AGC: OFF
H	AGC: ON

#### 7.3.2. Active gain control automatic time setting function

When using Active gain Control, it is possible to choose whether to use the internal settings as a condition necessary for operation or to automatically determine and set them by the TB67S579FTG. Set to the internal automatic measurement mode, and automatic measurement starts after 84 ms when the output current is energized by 600 mA or more when ENABLE=H and RESET\_X=L are energized. However, it is valid only once from the time the power is turned on. If the automatic measurement mode is selected, increase the VREF voltage.

**table 7.3.2 Active gain control automatic time setting function**

AGC_AUTO	Function
L	Internal Configuration Mode
H	Internal automatic measurement mode

#### 7.3.3. tblank setting function for charge (CTBALNK pin)

Depending on the motor characteristics (L value and R value), the current breakthrough during charging may be large, and the constant current control may be disturbed.

Therefore, it is possible to change the tblank settings for the Charge period.

The tblank time changes depending on the voltage value input to the CTBLANK pin.

Example: If CTBLANK=1V is entered, the tblank time for the charge period is 1.875  $\mu$ s. The setting changes in 0.156V steps.

Note: For the CTBLANK and STBLANK settings, set the sum of the Charge and Slow dead zone times to be longer than the dead zone time of ISD (1.25  $\mu$ s (typical)). If it is shorter than the ISD dead zone time, ISD may not be detected.

**table 7.3.3 tblank setting function for charge**

Val	tblank time [ $\mu$ s]	Val	tblank time [ $\mu$ s]
0	0.000	8	2.500
1	0.313	9	2.813
2	0.625	10	3.125
3	0.938	11	3.438
4	1.250	12	3.750
5	1.563	13	4.063
6	1.875	14	4.375
7	2.188	15	4.688

### 7.3.4. tblank setting function for Slow (STBLANK pin)

Set the tblank time of Slow by setting this terminal. The tblank time changes depending on the voltage value input to the STBLANK pin.

Example: If STBLANK=1V is entered, the tblank time for the slow period is 2.188  $\mu$ s. The setting changes in 0.156V steps.

Note: For the CTBLANK and STBLANK settings, set the sum of the Charge and Slow dead zone times to be longer than the dead zone time of ISD (1.25  $\mu$ s (typical)). If it is shorter than the ISD dead zone time, ISD may not be detected.

**table 7.3.4 TBLANK Configuration Function for Slow**

Val	tblank time [ $\mu$ s]	Val	tblank time [ $\mu$ s]
0	0.313	8	2.813
1	0.625	9	3.125
2	0.938	10	3.438
3	1.250	11	3.750
4	1.563	12	4.063
5	1.875	13	4.375
6	2.188	14	4.688
7	2.500	15	5.000

### 7.3.5. tblank setting function for motor M connection (MTBLANK terminal)

Due to the influence of the M-coupling of the motor, the AGC operation may become unstable. It is possible to improve stability by adjusting the Blank time by setting this terminal. The tblank time changes depending on the voltage value input to the MTBLANK pin.

Example: If MTBLANK=1V is entered, the tblank time is 1.875  $\mu$ s. The setting changes in 0.156V steps.

**table 7.3.5 tblank setting function for motor M**

Val	tblank time [ $\mu$ s]	Val	tblank time [ $\mu$ s]
0	0.000	8	2.500
1	0.313	9	2.813
2	0.625	10	3.125
3	0.938	11	3.438
4	1.250	12	3.750
5	1.563	13	4.063
6	1.875	14	4.375
7	2.188	15	4.688

### 7.3.6. NF Detection Hysteresis Setting Function (NFHYS Pin)

The output current is pierced from the NF point. In addition, the decay of the slow current decreases as the output current decreases, and it operates at a level that cannot be adjusted by tblank time alone. Due to the influence of the induced voltage generated during motor drive, the current may be lifted during the slow period. In order to stabilize the control, the NF is equipped with a function to have Hys.

Note: If NF\_HYS =1 V is entered, Val = 1. The setting changes in 0.625V steps.

**table 7.3.6 NF Detection Hysteresis Setting Function**

Val	NF_HYS settings	remarks
0	0	No change
1	1	Modified to match slow_hys fuse
2	2	Changing the slow_hys to match the DAC value
3	3	Changing the slow_hys to match the DAC value
4	Serial Registers	Uses Serial Registers

### 7.3.7. Motor Phase Delay Setting Function (TARGET\_ANGLE Pin)

Set the delay tolerance of the motor. This terminal can be used to adjust the extent to which the motor phase delay in AGC operation is tolerated. If it is set to an area that is not PWM controlled, the motor will go out of step. The voltage value input to the TARGET\_ANGLE pin changes the target phase. The amount of change is 1.406 [°], which can be set in 64 steps from 0 ~ 88.594 [°].

Note: The setting changes in 0.039V steps.

### 7.3.8. Active Gain Control Control Gain Setting Function (ACG\_KP Pin, AGC\_KI Pin)

This function adjusts the control gain for the influence of current pulse flow and load response during AGC operation. When you want to suppress the current pulse flow, lower the gain by using this setting terminal. If you want to increase the load response, increase the gain. The control gain changes depending on the voltage value input to the KP and KI pins. The amount of change is 8 [A/°], and 64 steps can be set from 0 ~ 504 [A/°].

Note: The setting changes in 0.039V steps.

### 7.3.9. Active Gain Control Attenuation Setting Function (VSP\_MIN Pin)

In AGC operation, when the load is light and torque is not required, the output current is attenuated, but if the damping is too much, the motor may go out of step. To prevent this, it is possible to set a lower limit for current decay in AGC operation. The lower limit of attenuation changes depending on the voltage value input to the VSP\_MIN terminal.

Note: If the VSP\_MIN is the VSP\_MIN > VREF pin input voltage, the value of the VREF pin is valid.

Note: The setting changes in 0.156V steps.

**table 7.3.9 Active Gain Control Attenuation Configuration Function**

Val	Lower current limit [A]	Val	Lower current limit [A]
0	0	8	1.001
1	0.125	9	1.126
2	0.250	10	1.251
3	0.375	11	1.376
4	0.500	12	1.501
5	0.626	13	1.627
6	0.751	14	1.752
7	0.876	15	1.877

### 7.3.10. Active Gain Control OFF Setting Function at Low Speed (FREQ\_MIN Pin)

It is set to turn off AGC at low speeds. In the AGC system, the induced voltage is detected and the current control is switched. Since the induced voltage cannot be detected normally at low speed of the motor, this function sets the frequency to turn off the AGC function at low speed. Since there is a Hys for switching, the setting frequency is shown in the table below. The frequency at which the AGC is turned off changes depending on the voltage value input to the FREQ\_MIN pin.

Example: When FREQ\_MIN = 1 V is input, Val = 6, and AGC is turned off when the rotation speed of the motor is 420-460 Hz or less.

Note: The setting changes in 0.156V steps.

**table 7.3.10 Low Speed Active Gain Control OFF Setting Function**

Val	Frequency [Hz]	Val	Frequency [Hz]	Val	Frequency [Hz]
0	1	6	420 to 460	12	840 to 920
1	66 to 88	7	488 to 536	13	920 to 996
2	140 to 152	8	560 to 616	14	967 to 1084
3	208 to 228	9	624 to 696	15	1038 to 1162
4	280 to 304	10	696 to 772	-	-
5	348 to 384	11	772 to 840	-	-

### 7.3.11. Active Gain Control Zero-Cross Localization Time Setting Function (AGC\_TIME Pin)

It is possible to set the time to specify the zero-crossing position with this terminal. This is a function to set the slow time of zero crossing. If AGC\_AUTO=H and the automatic measurement mode is used, no setting is required. Depending on the voltage value input to the AGC\_TIME terminal, the slow time of zero-crossing changes. The amount of change is 0.625 μs, and 512 steps can be set from 0 ~ 319.375 μs.

Note: The setting changes in 0.005V steps.

## 7.4. Continuous Micro-stepping Function

### 7.4.1. Continuous Micro-stepping Configuration Function

To set the Continuous Micro-stepping operation, set AGC\_ON = H, AWGS = H, ADMD = L. Continuous Micro-stepping can be configured. While the normal μStep changes the motor current in a step-like manner so that it becomes a pseudo-sine wave, the IC automatically completes the step clock and continuously changes the motor current so that it becomes a sine wave. Compared to μStep drive, it has the effect of reducing vibration during motor drive. It can only be set when ENABLE=L. If you select it, be sure to set it to ENABLE=L. When switching from other excitation operations to Continuous Micro-stepping, or when switching from it to other excitation operations, changes to settings during output operation will not be reflected. In addition, if the ADMD pin is switched during operation other than Continuous Micro-stepping (chopping operation), the setting will be reflected at the next Charge timing.

**table 7.4.1** Continuous Micro-stepping Configuration Function

AGC_ON	AWGS	ADMD	AGC_AUTO	Function
L	L	L	x	Normal μStep
L	L	H	x	Auto Decay Mode (Charge⇒Slow⇒Charge (Fast))
L	H	L	x	AWGS Operation
L	H	H	x	AWGS Operation (Auto Decay Mode)
H	L	L	x	Normal μStep
H	L	H	L	AGC Operation
H	L	H	H	AGC operation (internal automatic measurement mode)
H	H	L	x	Continuous Micro-stepping
H	H	H	L	AGC + AWGS
H	H	H	H	AGC + AWGS (Internal Automatic Measurement Mode)

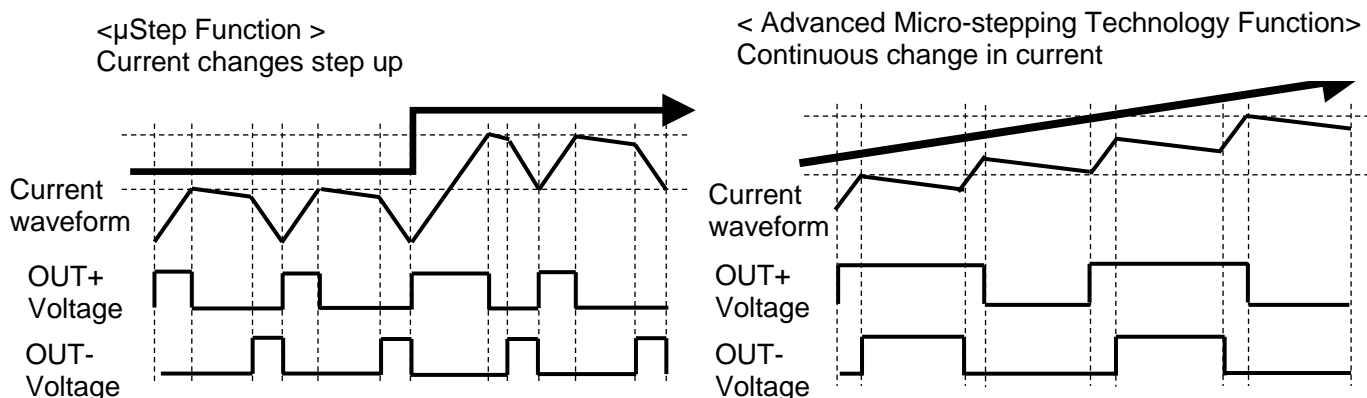

**Figure 7.4.1** μStep and Continuous Micro-stepping

## 7.4.2. Continuous Micro-stepping Control Gain Setting Function (KPKI\_NANO Pin)

During Continuous Micro-stepping operation, the operation may become unstable due to load fluctuations and induced voltages. Therefore, it becomes a function to adjust the control gain. The control gain changes depending on the voltage value input to the KPKI\_NANO terminal. Depending on the input voltage to this pin, 10 settings can be made as a combination. The setting changes in 0.313V steps.

**table 7.4.2** Continuous Micro-stepping Control Gain Setting Function

Val	Kp	Ki
0	128	160
1	128	304
2	128	608
3	256	160
4	256	304
5	256	608
6	512	160
7	512	304
8	512	608
9	IC Internal Settings (Kp_nano×2 <sup>4</sup> )	IC Internal Settings (Ki_nano×2 <sup>4</sup> )

## 7.4.3. AGC\_OUT Function

A reference signal that controls the output current during AGC operation is output from the AGC\_OUT pin. By monitoring this pin, it is possible to check the state of increase or decrease in output current without observing the output current. In addition, the serial setting (m\_dac\_sel) changes the signal output to the AGC\_OUT pin. If the detection position is selected in the serial setting, the rotor phase of the motor is output during AGC operation. When torque command output is selected, the AGC\_OUT terminal voltage = 0.75 V × output current. When position signal output is selected, the AGC\_OUT terminal voltage = 0.0166 V × electrical angle.

〈Normal control〉  
(To prevent step-out, operate with a margin of output current)

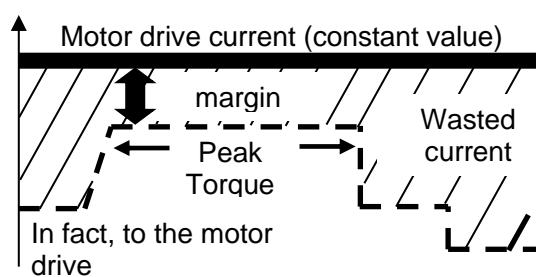

〈AGC Control〉  
(Automatic optimization of drive current according to the required torque)

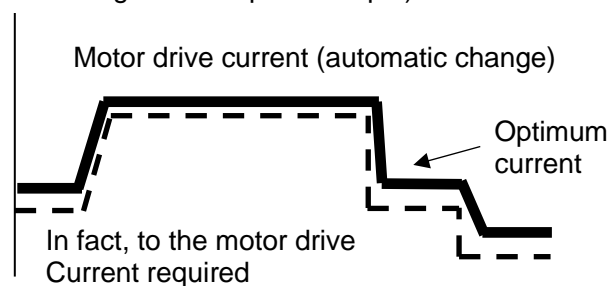

**Figure 7.4.3 Normal and AGC Control**

## 7.5. Serial Input Control

External terminal settings required for AGC operation and Continuous Micro-stepping operation can be set with a 2-wire serial with 2 terminals of SERIAL\_IN and SERIAL\_CLK. The commands that can be set in serial are as follows. In addition, the SERIAL\_IN is also a terminal for output serial data. It has a format similar to I2C, but does not have an acknowledge bit. Communication starts in the start condition (SERIAL\_CLK = SERIAL\_IN down edge during H) and ends communication in the stop condition (SERIAL\_IN up edge during SERIAL\_CLK = H). If the VM < 5V, the SERIAL\_IN control voltage should be less than or equal to the VM. If you want to enable the value changed in the serial settings, enter a 5V input (VREG level) to each parameter pin such as CTBLANK. When inputting a voltage from a different power supply other than the VREG pin output to each parameter pin, be sure to enter a voltage that can keep 2.5V or higher. Also, connect to GND when not in use.

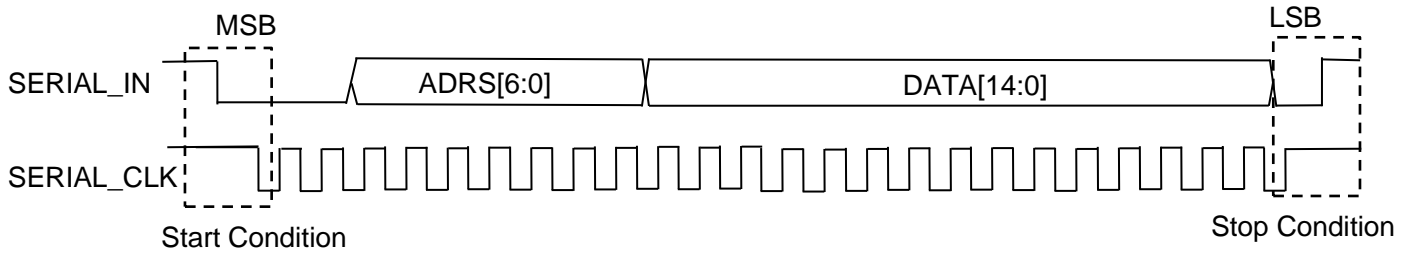

Figure 7.5 Serial Format

table 7.5 Register Map

Addr [6:0]	データ幅															
	D14	D13	D12	D11	D10	D9	D8	D7	D6	D5	D4	D3	D2	D1	D0	
0																
1				tsd_err_clear	isd_err_clear	stall_err_clear	open_err_clear					crc_err	tsd_lat	isd_lat	stall_det	open_det
2																
3																
4																
5																
6																
7																
8																
9																
10																
11																
12																
13																
14																
15																
16																
17																
18																
19																
20																
21																
22																
23																

### 7.5.1. Address 1

Clear each abnormal condition (TSD, ISD, Stall, Open).

**table 7.5.1 Address 1**

DATA Bit				Function
D11	D10	D9	D8	
tsd_err_clear	isd_err_clear	stall_err_clear	open_err_clear	
0	0	0	0	Initial value
-	-	-	1	OPEN Error Clearing
-	-	1	-	Clear Stall Errors
-	1	-	-	ISD Error Clearing
1	-	-	-	TSD Error Clearing

### 7.5.2. Address 2

Depending on the motor characteristics (L value and R value), the current breakthrough during charging may be large, and the constant current control may be disturbed.

Therefore, it is possible to change the tblank settings for the Charge period.

**table 7.5.2 Address 2**

DATA Bit				Function
D3	D2	D1	D0	
Ctblank				tblank time [ $\mu$ s]
0	1	0	0	Initial value (1.406)
0	0	0	0	0.156
0	0	0	1	0.469
0	0	1	0	0.781
0	0	1	1	1.094
0	1	0	0	1.406
0	1	0	1	1.719
0	1	1	0	2.031
0	1	1	1	2.344
1	0	0	0	2.656
1	0	0	1	2.969
1	0	1	0	3.281
1	0	1	1	3.594
1	1	0	0	3.906
1	1	0	1	4.219
1	1	1	0	4.531
1	1	1	1	4.844

### 7.5.3. Address 3

Set the tblank time of SLOW.

**table 7.5.3 Address 3**

DATA Bit				Function
D3	D2	D1	D0	
Stblank				tblank time [μs]
0	1	0	0	Initial value (1.563)
0	0	0	0	0.313
0	0	0	1	0.625
0	0	1	0	0.938
0	0	1	1	1.250
0	1	0	0	1.563
0	1	0	1	1.875
0	1	1	0	2.188
0	1	1	1	2.500
1	0	0	0	2.813
1	0	0	1	3.125
1	0	1	0	3.438
1	0	1	1	3.750
1	1	0	0	4.063
1	1	0	1	4.375
1	1	1	0	4.688
1	1	1	1	5.000

## 7.5.4. Address 4

Set the tblank time during Fast.

**table 7.5.4 Address 4**

DATA Bit				Function
D3	D2	D1	D0	
Ftblank				tblank time [μs]
0	1	0	0	Initial value (1.406)
0	0	0	0	0.156
0	0	0	1	0.469
0	0	1	0	0.781
0	0	1	1	1.094
0	1	0	0	1.406
0	1	0	1	1.719
0	1	1	0	2.031
0	1	1	1	2.344
1	0	0	0	2.656
1	0	0	1	2.969
1	0	1	0	3.281
1	0	1	1	3.594
1	1	0	0	3.906
1	1	0	1	4.219
1	1	1	0	4.531
1	1	1	1	4.844

## 7.5.5. Address 5

Due to the influence of the M-coupling of the motor, the AGC operation may become unstable. It is possible to increase stability by adjusting the Blank time with this setting.

**table 7.5.5 Address 5**

DATA Bit				Function
D3	D2	D1	D0	
Mtblank				tblank time [μs]
0	0	1	1	Initial value (0.938)
0	0	0	0	0.000
0	0	0	1	0.313
0	0	1	0	0.625
0	0	1	1	0.938
0	1	0	0	1.250
0	1	0	1	1.563
0	1	1	0	1.875
0	1	1	1	2.188
1	0	0	0	2.500
1	0	0	1	2.813
1	0	1	0	3.125
1	0	1	1	3.438
1	1	0	0	3.750
1	1	0	1	4.063
1	1	1	0	4.375
1	1	1	1	4.688

## 7.5.6. Address 6

In AGC operation, when the load is light and torque is not required, the output current is attenuated, but if the damping is too much, the motor may go out of step. To prevent this, it is possible to set a lower limit for current decay in AGC operation.

**table 7.5.6 Address 6**

DATA Bit				Function
D3	D2	D1	D0	
vsp_min				Lower current limit [A]
0	0	1	0	Initial value (0.250)
0	0	0	0	0
0	0	0	1	0.125
0	0	1	0	0.250
0	0	1	1	0.375
0	1	0	0	0.500
0	1	0	1	0.626
0	1	1	0	0.751
0	1	1	1	0.876
1	0	0	0	1.001
1	0	0	1	1.126
1	0	1	0	1.251
1	0	1	1	1.376
1	1	0	0	1.501
1	1	0	1	1.627
1	1	1	0	1.752
1	1	1	1	1.877

### 7.5.7. Address 7

The output current is pierced from the NF point. In addition, the decay of the slow current decreases as the output current decreases, and it operates at a level that cannot be adjusted by tblank time alone. Due to the influence of the induced voltage generated during motor drive, the current may be lifted during the slow period. In order to stabilize the control, the NF is equipped with a function to have Hys.

**table 7.5.7 Address 7**

DATA Bit		Function
D1	D0	
nf_hys		
0	1	Initial value
0	0	No change
0	1	Internal settings
1	0	With the magnitude of the Ustep command value The amount of change changes
1	1	

### 7.5.8. Address 8

It is set to turn off AGC at low speeds. In the AGC system, the induced voltage is detected and the current control is switched. Since the induced voltage cannot be detected normally at low speed of the motor, this function sets the frequency to turn off the AGC function at low speed. Since there is a Hys for switching, the setting frequency is shown in the table below.

**table 7.5.8 Address 8**

DATA Bit				Function
D3	D2	D1	D0	
Freq_min				Frequency [Hz]
0	0	0	0	Initial value (66 to 88)
0	0	0	0	1
0	0	0	1	66 to 88
0	0	1	0	140 to 152
0	0	1	1	208 to 228
0	1	0	0	280 to 304
0	1	0	1	348 to 384
0	1	1	0	420 to 460
0	1	1	1	488 to 536
1	0	0	0	560 to 616
1	0	0	1	624 to 696
1	0	1	0	696 to 772
1	0	1	1	772 to 840
1	1	0	0	840 to 920
1	1	0	1	920 to 996
1	1	1	0	967 to 1084
1	1	1	1	1038 to 1162

### 7.5.9. Address 9

Set the wait time for agc\_auto detection.

**table 7.5.9 Address9**

DATA Bit			Function
D2	D1	D0	
nf_hys			Wait time [ms]
1	0	0	Initial value (80.00 to 80.04)
0	0	0	5.00 to 5.04
0	0	1	10.00 to 10.04
0	1	0	20.00 to 20.04
0	1	1	40.00 to 40.04
1	0	0	80.00 to 80.04
1	0	1	100.00 to 100.04
1	1	0	120.00 to 120.04
1	1	1	160.00 to 160.04

### 7.5.10. Address 10

It is possible to set the time to determine the zero-crossing position. This is a function to set the slow time of zero crossing. The amount of change is 0.625  $\mu$ s, and 512 steps can be set from 0 to 319.375  $\mu$ s.

**table 7.5.10 Address 10**

DATA Bit									Function
D8	D7	D6	D5	D4	D3	D2	D1	D0	
Agc_time									Zero Crossing Slow Time [Hz]
0	0	0	1	1	0	0	1	0	Initial value (31.25)
0	0	0	0	0	0	0	0	0	0.000
0	0	0	0	0	0	0	0	1	0.625
0	0	0	0	0	0	0	1	0	1.250
0	0	0	0	0	0	0	1	1	1.875
0	0	0	0	0	0	1	0	0	2.500
⋮									
1	1	1	1	1	1	0	0	1	315.625
1	1	1	1	1	1	0	1	0	316.250
1	1	1	1	1	1	0	1	1	316.875
1	1	1	1	1	1	1	0	0	317.500
1	1	1	1	1	1	1	0	1	318.125
1	1	1	1	1	1	1	1	0	318.750
1	1	1	1	1	1	1	1	1	319.375

## 7.5.11. Address 11

This function adjusts the control gain for the influence of current pulse flow and load response during AGC operation. When you want to suppress the current pulse flow, lower the gain by using this setting terminal. If you want to increase the load response, increase the gain. The amount of change is 8 [A/°], and 64 steps can be set from 0 ~ 504 [A/°].

**table 7.5.11 Address 11**

DATA Bit						Function
D5	D4	D3	D2	D1	D0	
Ki						A/°
0	1	0	0	0	0	Initial value (128)
0	0	0	0	0	0	0
0	0	0	0	0	1	8
0	0	0	0	1	0	16
0	0	0	0	1	1	24
0	0	0	1	0	0	32
⋮						
1	1	1	0	0	1	456
1	1	1	0	1	0	464
1	1	1	0	1	1	472
1	1	1	1	0	0	480
1	1	1	1	0	1	488
1	1	1	1	1	0	496
1	1	1	1	1	1	504

## 7.5.12. Address 12

This function adjusts the control gain for the influence of current pulse flow and load response during AGC operation. When you want to suppress the current pulse flow, lower the gain by using this setting terminal. If you want to increase the load response, increase the gain. The amount of change is 8 [A/°], and 64 steps can be set from 0 ~ 504 [A/°].

**table 7.5.12 Address 12**

DATA Bit						Function
D5	D4	D3	D2	D1	D0	
Kp						A/°
1	1	1	1	1	1	Initial value (504)
0	0	0	0	0	0	0
0	0	0	0	0	1	8
0	0	0	0	1	0	16
0	0	0	0	1	1	24
0	0	0	1	0	0	32
⋮						
1	1	1	0	0	1	456
1	1	1	0	1	0	464
1	1	1	0	1	1	472
1	1	1	1	0	0	480
1	1	1	1	0	1	488
1	1	1	1	1	0	496
1	1	1	1	1	1	504

## 7.5.13. Address 13

Set the delay tolerance of the motor. This terminal can be used to adjust the extent to which the motor phase delay in AGC operation is tolerated. If it is set to an area that is not PWM controlled, the motor will go out of step. The voltage value input to the TARGET\_ANGLE pin changes the target phase. The amount of change is 1.406 [°], which can be set in 64 steps from 0 ~ 88.578 [°].

**table 7.5.13 Address13**

DATA Bit						Function
D5	D4	D3	D2	D1	D0	
target_angle						Target electric angle [°]
1	0	1	0	1	0	Initial value (59.052)
0	0	0	0	0	0	0
0	0	0	0	0	1	1.406
0	0	0	0	1	0	2.812
0	0	0	0	1	1	4.218
0	0	0	1	0	0	5.624
⋮						
1	1	1	0	0	1	80.142
1	1	1	0	1	0	81.548
1	1	1	0	1	1	82.954
1	1	1	1	0	0	84.360
1	1	1	1	0	1	85.766
1	1	1	1	1	0	87.172
1	1	1	1	1	1	88.578

## 7.5.14. Address 14

Sets the error for the differential electric angle of zero-crossing detection. The amount of change is 1.406 [°], which can be set in 64 steps from 0 ~ 88.578 [°].

**table 7.5.14 Address 14**

DATA Bit						Function
D5	D4	D3	D2	D1	D0	
Err_delta						Differential electric angle [°]
1	1	0	0	0	0	Initial value (67.488)
0	0	0	0	0	0	0
0	0	0	0	0	1	1.406
0	0	0	0	1	0	2.812
0	0	0	0	1	1	4.218
0	0	0	1	0	0	5.624
⋮						
1	1	1	0	0	1	80.142
1	1	1	0	1	0	81.548
1	1	1	0	1	1	82.954
1	1	1	1	0	0	84.360
1	1	1	1	0	1	85.766
1	1	1	1	1	0	87.172
1	1	1	1	1	1	88.578

## 7.5.15. Address 15

During Continuous Micro-stepping operation, the operation may become unstable due to load fluctuations and induced voltages. Therefore, it becomes a function to adjust the control gain.

**table 7.5.15** Address15

DATA Bit						Function
D5	D4	D3	D2	D1	D0	
ki_nano						Continuous Micro-stepping ki [%/A]
0	0	1	0	1	0	Initial value (160)
0	0	0	0	0	0	0
0	0	0	0	0	1	16
0	0	0	0	1	0	32
0	0	0	0	1	1	48
0	0	0	1	0	0	64
⋮						
1	1	1	0	0	1	912.000
1	1	1	0	1	0	928.000
1	1	1	0	1	1	944.000
1	1	1	1	0	0	960.000
1	1	1	1	0	1	976.000
1	1	1	1	1	0	992.000
1	1	1	1	1	1	1008.000

### 7.5.16. Address 16

During Continuous Micro-stepping operation, the operation may become unstable due to load fluctuations and induced voltages. Therefore, it becomes a function to adjust the control gain.

**table 7.5.16 Address16**

DATA Bit						Function
D5	D4	D3	D2	D1	D0	
kp_nano						Continuous Micro-stepping kp [%/A]
0	0	1	0	0	0	Initial value (128)
0	0	0	0	0	0	0
0	0	0	0	0	1	16
0	0	0	0	1	0	32
0	0	0	0	1	1	48
0	0	0	1	0	0	64
⋮						
1	1	1	0	0	1	912.000
1	1	1	0	1	0	928.000
1	1	1	0	1	1	944.000
1	1	1	1	0	0	960.000
1	1	1	1	0	1	976.000
1	1	1	1	1	0	992.000
1	1	1	1	1	1	1008.000

### 7.5.17. Address 17

Set the open detection width for the Continuous Micro-stepping.

**table 7.5.17 Address17**

DATA Bit		Function
D1	D0	
odet_nano		Detection Width Count
0	0	Initial value (9 (9 / set current value*511))
0	0	9 (9 / set current value*511)
0	1	5 (Minimum current: 5 / Set current value*511)
1	0	18 (Minimum current: 18 / Set current value*511)
1	1	27 (Minimum current: 27 / Set current value*511)

### 7.5.18. Address 18

Sets the waiting time until the start of SW control at the time of Continuous Micro-stepping.

**table 7.5.18 Address18**

DATA Bit		Function
D1	D0	
wait_nano		Wait time [μs]
1	0	Initial value (0.47)
0	0	0.00
0	1	0.23
1	0	0.47
1	1	0.78

### 7.5.19. Address 19

Set the waiting time before AD conversion at the time of Continuous Micro-stepping.

**table 7.5.19 Address19**

DATA Bit			Function
D2	D1	D0	
ad_wait_nano			Wait time [μs]
0	0	0	Initial value (0.23)
0	0	0	0.23
0	0	1	0.47
0	1	0	0.78
0	1	1	1.25
1	0	0	1.48
1	0	1	1.72
1	1	0	1.95
1	1	1	2.27

### 7.5.20. Address 20

Set the boost. Depending on the setting, the differential setting value of the electric angle in the error count during AGC operation changes.

**table 7.5.20 Address20**

DATA Bit			Function								
D2	D1	D0	Number of consecutive errors								
boost_sel			0	1	2	3	4	5	6	7	8
0	0	0	Initial value (2047)								
0	0	0	1023								
0	0	1	2047								
0	1	0	4095								
0	1	1	1023				8191				
1	0	0	1023				4095				
1	0	1	2047				4095				
1	1	0	1023	2047	4095				8191		
1	1	1	1023	2047	4095				8191		

### 7.5.21. Address 21

Select internal RS mode and external RS resistance mode. External RS mode only works for normal  $\mu$ Step operation.

**table 7.5.21 Address 21**

DATA Bit	Function
D0	Function
RS	
0	
0	Internal RS Mode
1	External RS Resistor Mode

### 7.5.22. Address 22

Select the auto-return/latch mode for the TSD function. Automatic recovery is automatically restored depending on the temperature state. In latch mode, once a TSD is detected, the output remains in a stopped state.

**table 7.5.22 Address22**

DATA Bit	Function
D0	Function
TSD_Auto	
1	
0	Automatic recovery
1	latch

### 7.5.23. Address 23

The m\_dac\_sel selects the signal to be output from the AGC\_OUT terminal. odet\_mask is a mask function for open detection. When open detection is disabled, no error is output from the LO pin.

**table 7.5.23 Address 23 (D0)**

DATA Bit	Function
D0	
m_dac_sel	
0	Initial value (Torque command output ( $0.75 \text{ V} * \text{Output Current}$ ))
0	Torque command output ( $0.75 \text{ V} * \text{Output Current}$ )
1	Detection position signal output ( $0.0166 \text{ V} * \text{Electrical Angle}$ )

**table 7.5.24 Address 23 (D1)**

DATA Bit	Function
D1	
odet_mask	
0	Initial value (Open Detection Enabled)
0	Open Detection Enabled
1	Open Detection Disabled

## 7.6. Output Stage Transistor Operating Mode

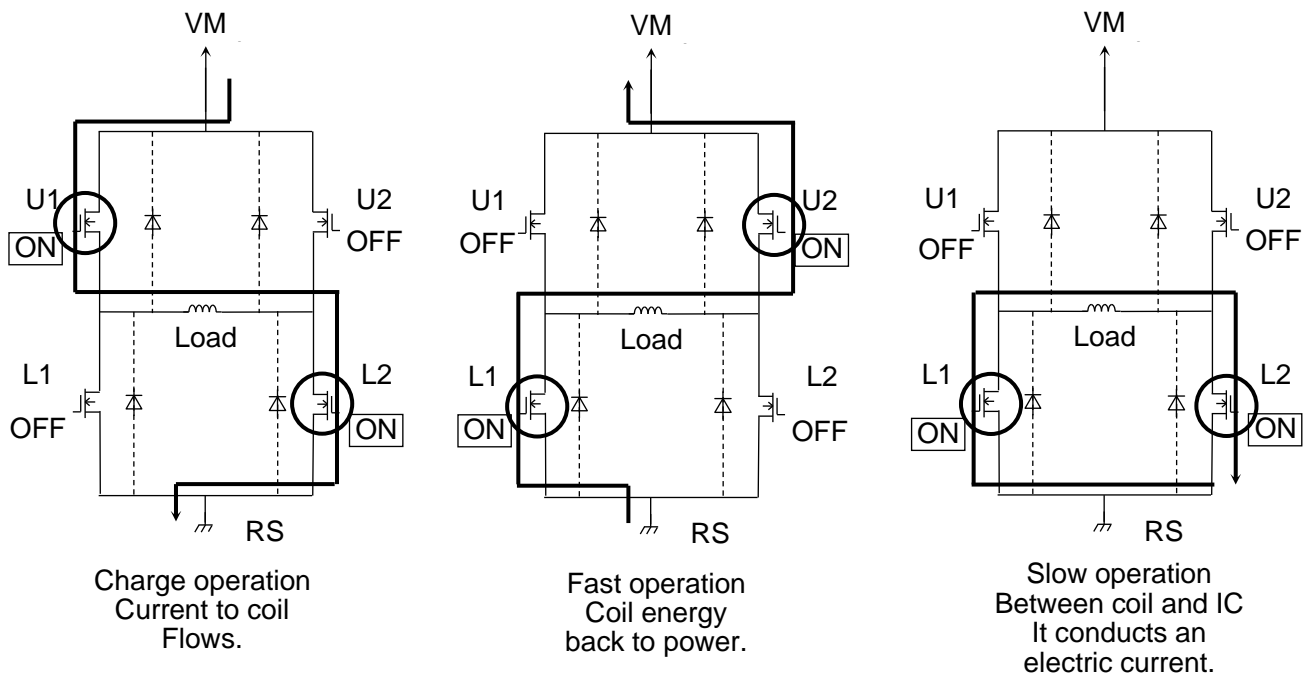

**Figure 7.6 Output Stage Transistor Operating Mode**

Note: When switching outputs, there is a penetration prevention time inside the IC to prevent through current.

### 7.6.1. Functions of Output Stage Transistor Operation

**table 7.6.1 Functions of Output Stage Transistor Operation**

Mode	U1	U2	L1	L2
CHARGE	ON	OFF	OFF	ON
FAST	OFF	ON	ON	OFF
SLOW	OFF	OFF	ON	ON

NOTE : The above table is an example of a current flowing in the direction of the arrow in the figure above. In the opposite direction, it is as shown in the table below.

Mode	U1	U2	L1	L2
CHARGE	OFF	ON	ON	OFF
FAST	ON	OFF	OFF	ON
SLOW	OFF	OFF	ON	ON

This IC automatically switches between three modes as shown in the figure above to perform constant current control.

Note: Equivalent circuits are partially omitted or simplified to explain the circuit.

## 7.6.2. Setting Current (IOUT)

The set current value during constant-current PWM control can be determined by setting the reference voltage (VREF).

The set current value (IOUT) can be calculated by the following equation:

$$I_{OUT} = V_{REF} \times 0.556$$

Example: If  $V_{REF} = 2.0\text{ V}$ ,  $I_{OUT} = 1.11\text{ A}$ .

In RS mode, the set current value can be determined by the reference voltage (VREF) and an external RS resistor.

The set current value (IOUT) can be calculated by the following equation:

$$I_{OUT} = V_{REF} / R_S / 5$$

Example: If  $V_{REF} = 2.0\text{ V}$  and  $R_S$  resistance =  $0.22\ \Omega$ ,  $I_{OUT} = 1.82\text{ A}$ .

Note: For external  $R_S$  resistors, please meet the  $R_S$  resistor value of  $0.4 > I_{out} \times R_S$ .

## 7.6.3. Chopping frequency (fCHOP)

The chopping frequency of the constant current control of the motor current can be set by the resistor ROSC connected to the OSCM pin. It can also be used at a fixed chopping frequency without any external components on the OSCM pin.

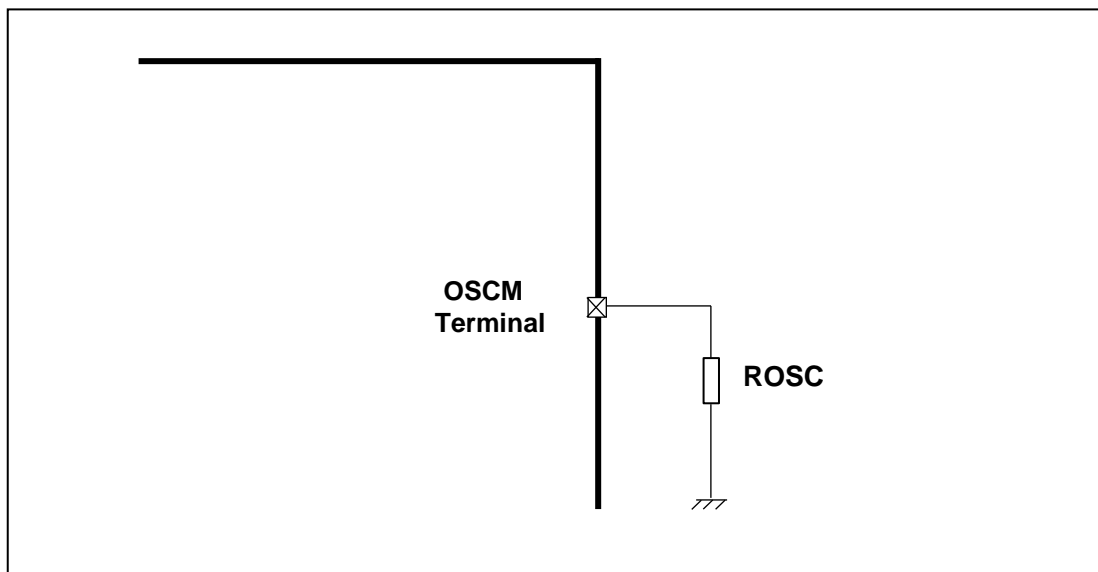

Note: Equivalent circuits may be omitted or simplified in order to explain the circuit.

**Figure 7.6.3 OSCM pin equivalent circuit**

The chopping frequency (fCHOP) can be calculated using the following formula:  
In general, it is recommended to set the frequency range from 40 kHz to 100 kHz based on a frequency of about 70 kHz.

$$f_{CHOP} = f_{OSCM} / 16$$

$$f_{OSCM} = 1 / (\alpha \times R_{OSC} + \beta) \quad [\text{MHz}] \quad \alpha = 1.7 \times 10^{-5}, \quad \beta = 0.0285$$

Example:  $f_{OSCM} = 1.2\text{ MHz}$  (typ.),  $f_{CHOP} = 75\text{ kHz}$  (typ.), when  $R_{OSC} = 47\text{ k}\Omega$

When the OSCM pin is open or shorted to GND, the IC operates at the automatically generated frequencies  $f_{OSCM2} = 800\text{ kHz}$  (typical) and  $f_{CHOP} = 50\text{ kHz}$  (typical).

## 7.6.4. Power Consumption of ICs

The power consumed by the IC can be roughly divided into two parts: the power consumed by the transistor in the output section and the power consumed by the logic section.

### 7.6.4.1. Power Consumption of Power Transistors

The power of the output section is consumed by the transistors above and below the H-bridge.

The power of the transistor section of one H-bridge can be expressed by the following equation:

$$P(\text{out}) = I_{\text{out}}(\text{A}) \times V_{\text{DS}}(\text{V}) = I_{\text{out}}(\text{A})^2 \times R_{\text{on}}(\Omega) \dots \dots \dots (1)$$

When a full step operation is performed and the output current waveform becomes a perfect square waveform, the average power consumption of the output is as follows It can be calculated.

Assuming  $R_{\text{on}} = 0.6\Omega$ ,  $I_{\text{out}}(\text{peak} : \text{Max}) = 1.0 \text{ A}$ , and  $V_{\text{M}} = 24 \text{ V}$ , the calculation is as follows.

$$\begin{aligned} P(\text{out}) &= 2(\text{Tr}) \times 1.0(\text{A})^2 \times 0.6(\Omega) \dots \dots \dots (2) \\ &= 1.2(\text{W}) \end{aligned}$$

### 7.6.4.2. Power Consumption of Logic and IM System

The power consumption of the logic and IM systems is calculated separately during operation and stoppage.

- $I(\text{IM3}) = 10.5\text{mA}(\text{typ.})$  : Operating
- $I(\text{IM2}) = 7.5\text{mA}(\text{typ.})$  : Stop
- $I(\text{IM1}) = 0.03\mu\text{A}(\text{typ.})$  : Standby

The output system is connected to the VM (24V). (Output system: The current consumed by the circuit connected to the VM and the output stage are  
The sum of the currents dissipated by switching)

Power consumption can be estimated as follows:

$$\begin{aligned} P(\text{IM3}) &= 24(\text{V}) \times 0.0105(\text{A}) \dots \dots \dots (3) \\ &= 0.252(\text{W}) \end{aligned}$$

### 7.6.4.3. Power Consumption

From the results of 1 and 2, the overall power consumption P can be calculated as follows:

$$P = P(\text{out}) + P(\text{IM3}) = 1.452(\text{W}).$$

In addition, the power consumption for one axis during standby is as follows.

$$P(\text{Standby}) = 24(\text{V}) \times 0.03(\mu\text{A}) = 0.72(\mu\text{W})$$

Regarding the thermal design of the board, etc., it should be set with a margin after sufficient mounting evaluation.

## 7.6.5. Detection function

It is equipped with the following detection functions.

**table 7.6.5 Detection function**

Detection function	Detection location	Detection level	Detection behavior	How to recover from the detection state
Overtemperature Detection (TSD)	Chip temperature	160°C (typical) or higher 5.0 μs (typical) dead zone time available	Full output forced OFF	This function is a latch type that maintains the operation at the time of detection. Returned by one of the following processes. - Power cycle - Set to sleep mode and then set to normal operation mode again.
Overcurrent Detection (ISD)	Output current	3 A (typical) or more 1.25 μs (typical) dead zone time available	Full output forced OFF	
Low supply voltage (UVLO)	VM terminal voltage	4.0 V (typical) or less 1.41 μs (typical) dead zone time available	Full output forced OFF Internal Circuit Reset	Increases VM voltage to >4.2V (typical)

### 7.6.5.1. Overtemperature Detection (This function is a latch type that maintains operation at the time of detection)

This function temporarily stops the operation of the IC when the device overheats abnormally. For overtemperature detection, the dead zone time is set to prevent false detection due to noise flying in from the outside. If overheating is detected, all channels are turned off. In automatic recovery mode, there is a dead zone time of 5 μs even during recovery.

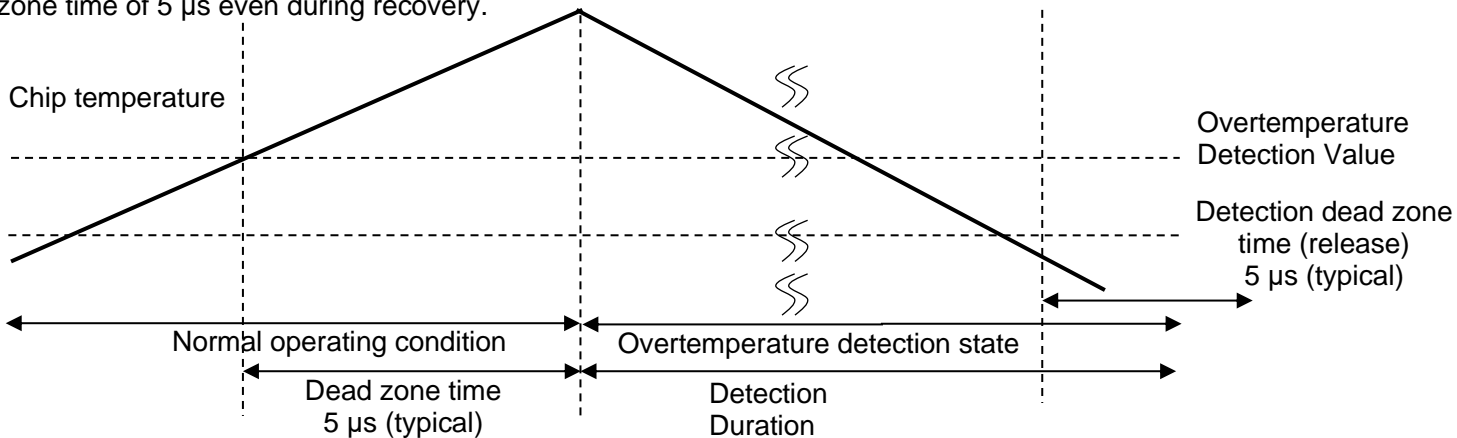

**Figure 7.6.5.1.1 Overtemperature Detection**

Note: Timing charts may be simplified for explanatory purposes. The value in the timing chart is the reference value.

● When overheating is detected

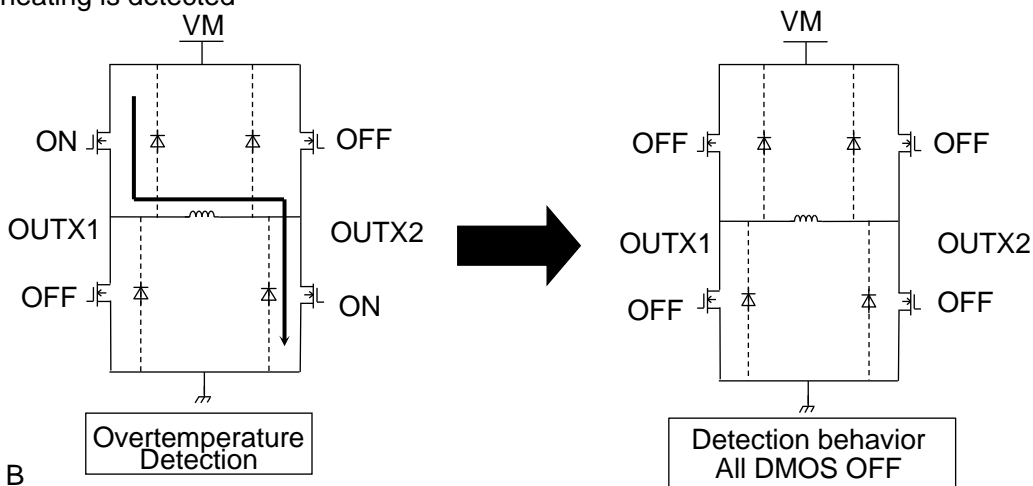

Note: X=A or B

**Figure 7.6.5.1.2 When overheating is detected**

## 7.6.5.2. Overcurrent Detection (This function is a latch type that maintains operation at the time of detection)

This function temporarily stops the operation of the IC when a short circuit, ceiling fault, or ground fault abnormality occurs between the outputs of the motor. For overcurrent detection, the dead zone time is set to prevent false detection due to spike currents during switching and external noise jumping. If an overcurrent is detected, both channels are turned off, not just the corresponding channel.

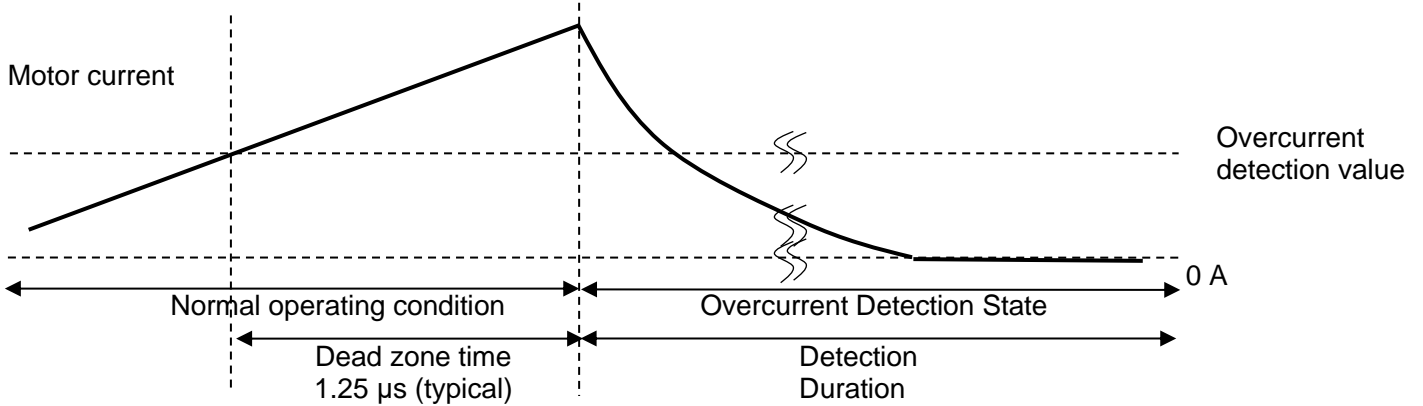

**Figure 7.6.5.2.1 Overcurrent Detection**

Note: Timing charts may be simplified for explanatory purposes. The value in the timing chart is the reference value.

- When an overcurrent is detected in the DMOS section on the lower side of the H-bridge due to a ceiling circuit at the output terminal

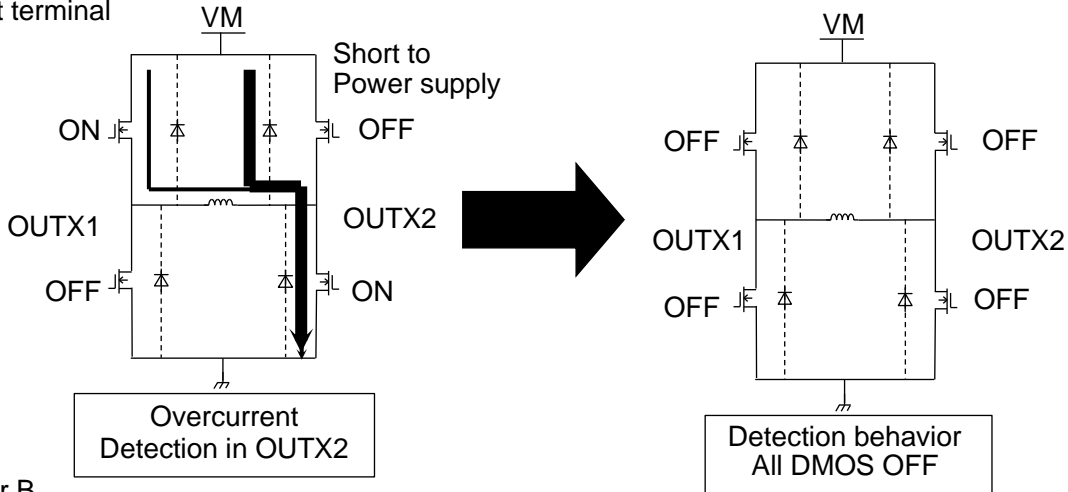

Note: X=A or B

**Figure 7.6.5.2.2 When an overcurrent is detected in the DMOS section (1)**

- When an overcurrent is detected in the DMOS section on the upper side of the H-bridge due to a ground fault in the output terminal

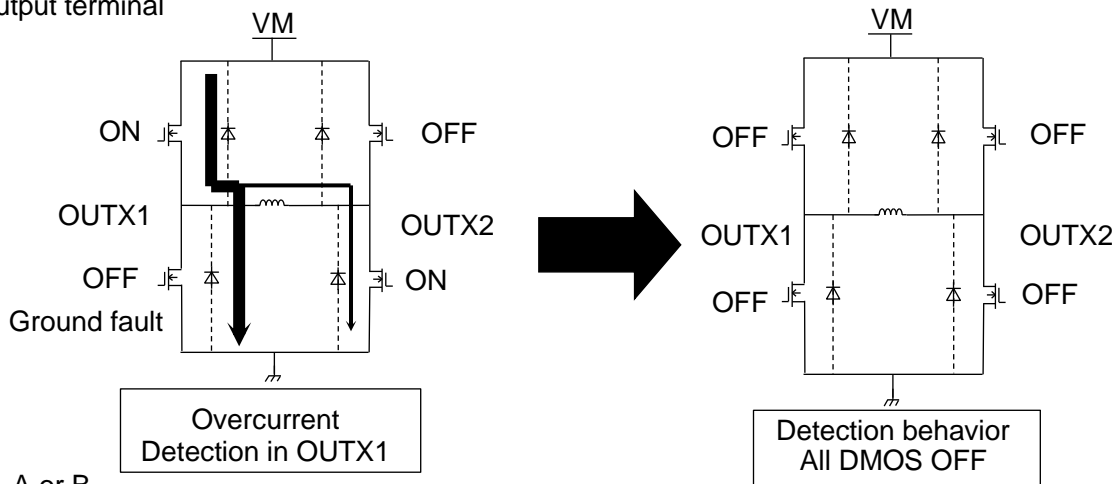

Note: X=A or B

**Figure 7.6.5.2.3 When an overcurrent is detected in the DMOS section (2)**

## 7.7. Stall Detection (SD : Stall Detection) Function

When a motor stall (step-out) is detected, L is output from the LO0, 1, and 2 pins.

**table 7.7 Stall Detection**

state	L0,L1,L2
Normal (normal operation)	High impedance
When stall (step-out) is detected	All : L

### Operation description

During the period when the current level is set to 0 (zero) A during motor rotation operation, the potential difference between the two ends of the motor coil (OUT\_A+ terminal and OUT\_A-terminal and OUT\_B+ terminal and OUT\_B-terminal) is normally generated by the induced voltage, but when the motor is stopped, the motor does not generate an induced voltage, so no voltage is generated at both ends of the motor coil.

In this function, when the induced voltage of the motor is not generated above a certain voltage during the same period, the rotation of the motor is considered to be stalled as it has stopped.

### 7.7.1. Stall Detection Circuit

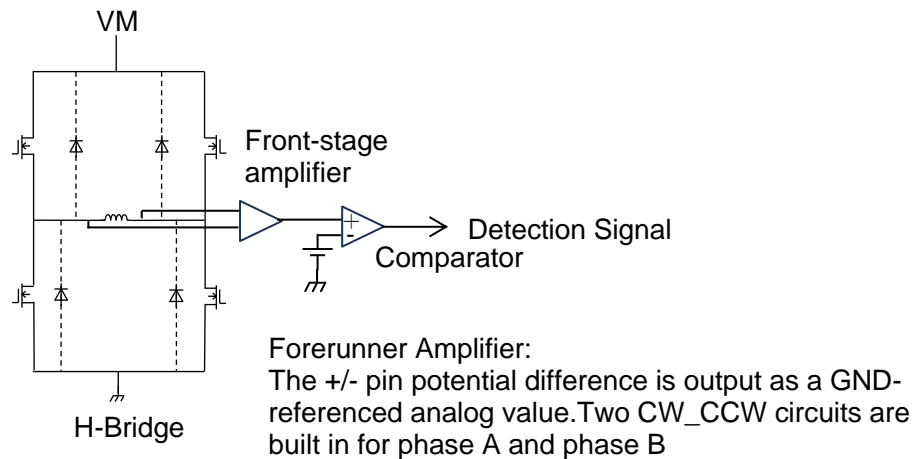

**Figure 7.7.1 Stall Detection Circuit**

### 7.7.2. Set Stall Detection Threshold

It is set by applying a voltage to the STOP\_DET\_VTH terminal.

- The motor-induced voltage is directly compared with the VSdT voltage applied inside the IC.
- Set the STOP\_DET\_VTH terminal applied voltage within the range of 0V~3.0V.
- If the VM < 6V or less, set the applied voltage of the STOP\_DET\_VTH pin to 1.9V or less.

If you do not want to use a function that does not use this function, set the STOP\_DET\_VTH pin to open.

### 7.7.3. When using the stall detection function

- When the motor is rotated in full step and Continuous Micro-stepping, the stall detection function does not work. (In full step and Continuous Micro-stepping, there is no period of setting the current level 0 (zero) A.)
- If the induced voltage is not sufficiently induced at low speed or depending on the type of motor, the stall detection function may not work properly  
It is. Please check the motor characteristics and drive conditions in advance before setting the threshold value.
- For example, when the motor is started from a standstill, the speed is slow and the induced voltage is not sufficiently induced, so the stall detection function may not work properly. This period should be excluded in order for the stall detection feature to be used effectively.
- Even if a stall is detected, the motor drive output will continue to be energized. The stall detection circuit does not change the motor drive output state.

## 7.7.4. Timing Chart (Stall Detection)

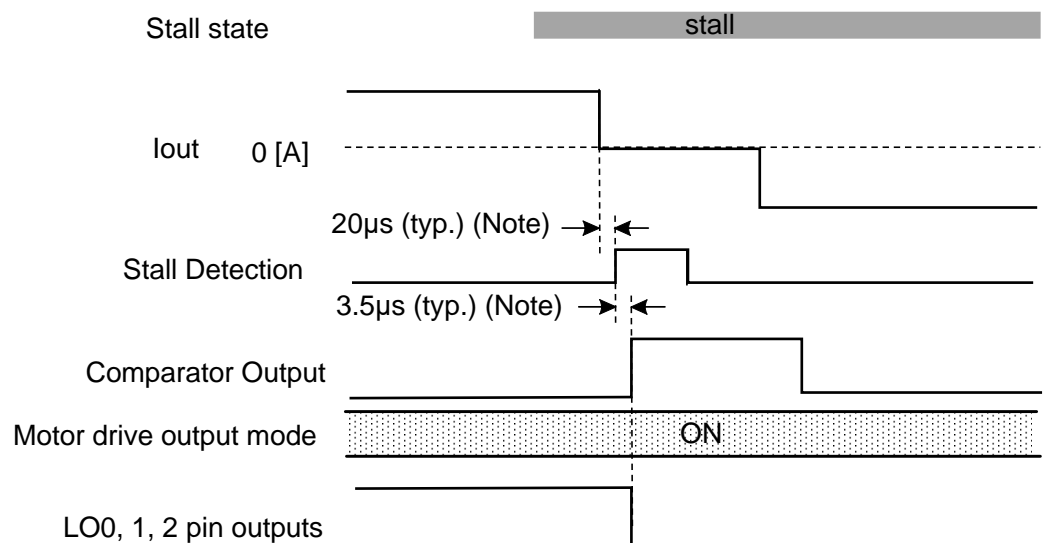

**Figure 7.7.4 Stall Detection Timing Chart**

Note: Not included in the shipping inspection item

The rise and fall timing of the LO0, 1, and 2 terminal output signals is not synchronized with other signals such as CLK.

Note: The timing chart has been simplified to illustrate the function and operation.

Note: Even if a µStep of 1-2 phases or more is selected, it cannot be detected normally if the region with a current of 0% (which becomes a current of 0A) is less than 20µs.

## 7.8. CRC error function

The data of the internal Fuse bit is reflected when the power is turned on at startup or when sleep is canceled, but if there is a reading error when reflecting, the output will be set to Hiz. When an error occurs, the internal Fuse data is read repeatedly until it is properly reflected.

CRC errors can be read serially.

## 8. Absolute maximum rating (Ta=25°C)

table 8. Absolute Maximum Ratings

item	symbol	Rated	unit
Motor power supply voltage	VM	35	V
Motor Output Voltage	VOUT	40	V
Motor output current (Note 1)	IOUT	2.0	A
Internal Regulator Voltage	VCC	6.0	V
Logic Input Pin Voltage	VIN	6.0	V
Vref reference voltage	Vref	6.0	V
MO, LO0, 1, 2 terminal voltage	VMO	6.0	V
Allowable power loss	IC alone (Note2)	1.3	W
	JEDEC 4-layer board (Note3)	4.1	
Operating Temperature	Topr	-40 ~ 85	°C
Storage temperature	Tstg	-55 ~ 150	°C
Junction temperature	Tj(MAX)	150	°C

Note1: The maximum current value under normal conditions should be calculated to be equivalent to 1 or 1.8 A or less.  
Depending on the ambient temperature and substrate conditions, the current may be further limited due to heat generation conditions.

Note2: When the IC is alone (Ta = 25°C), if Ta exceeds 25°C, derating must be performed at 10.4mW/°C.

Note3: JEDEC 4-layer board (Board size: 76.2 mm × 114.3 mm ,Ta = 25 °C)  
When Ta exceeds 25 °C, derating with 32.8 mW / °C is necessary.

- Ta : The ambient temperature of the IC.
- Topr : The ambient temperature of the IC when it is operated.
- Tj : The chip temperature of the IC during operation. The Tj maximum value is limited by the temperature of the TSD (Thermal Shutdown Circuit).

It is recommended that the maximum value of Tj be designed in consideration of the maximum current to be used, with a target of about 120°C.

### Absolute Maximum Ratings

The absolute maximum rating is a standard that should not be exceeded even instantaneously. Exceeding the absolute maximum rating may cause destruction, degradation, or damage to the IC, and may cause destruction, damage, or degradation of the IC as well. Ensure that the design does not exceed the absolute maximum rating under any operating conditions. In addition, this product does not have an overvoltage detection circuit. Therefore, if an excessive voltage above Spec is applied, the IC will be destroyed.

Please be sure to use each voltage range, including the power supply voltage, within the range of Spec. For more information on these precautions, please refer to the Notes section on the following page.

## 9. PD-Ta graph (for reference)

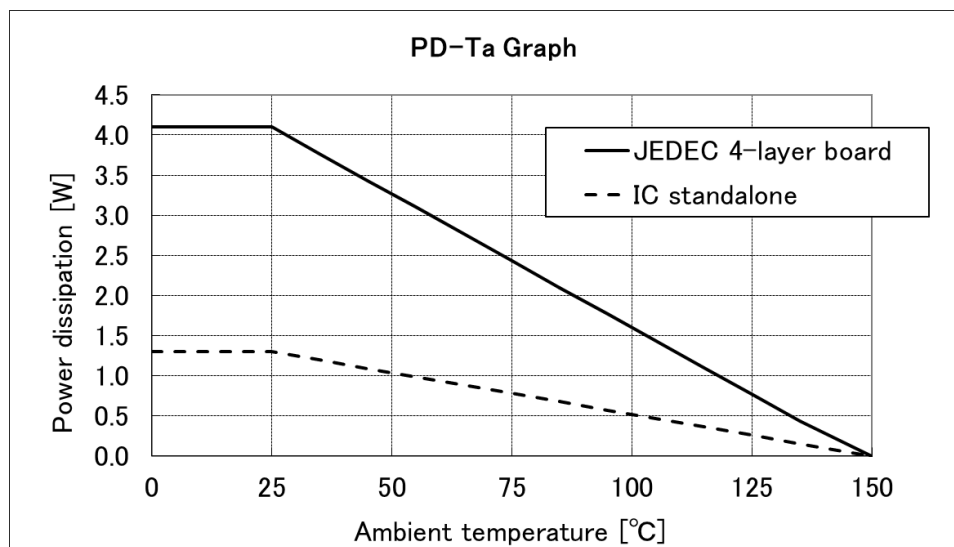

Figure 9. PD-Ta graph

## 10. Operating Range(Ta=-40 to 85°C)

table 10. Operating range

Characteristics	symbol	Min	Typ.	Max	Unit	remarks
Motor power supply voltage (Note 1)	VM	4.5	24.0	34	V	-
Motor output current	IOOUT	-	-	1.8	A	Equivalent to 1 (Note 2)
Logic Input Voltage	VIN(H)	2.0	-	5.5	V	H-Level of Logic
	VIN(L)	-0.5	-	0.8	V	L-Level of Logic
Chopping Frequency	fCHOP	40	70	150	kHz	-
Clock Frequency	fCLK1	-	-	250	kHz	-
Minimum clock frequency when AGC/AWGS/Continuous Micro-stepping function is enabled	fCLK2	1	-	-	Hz	-
Vref reference voltage	VREF	0	-	3.6	V	-
VSD Voltage	VSD	0.75	0.9	1.035	V	-

Note 1: It is recommended to use a slew rate of 0 V to 10 V at the time of power-up under conditions of 1 ms or more.

Note 2: The maximum current that can actually be used may be limited by the operating environment (operating conditions such as excitation mode and operating time, heat generation conditions such as ambient temperature conditions, and board conditions). After calculating the heat under the operating environment, check the maximum current value that can actually be used.

## 11. Electrical Characteristics

### 11.1. Electrical Characteristics 1 (Ta = -40 to 85°C unless otherwise specified)

table 11.1 Operating range

Characteristics		symbol	Test conditions	Min	Typ.	Max	unit
Logic Input Terminals Input voltage	High	VIN(H)	Logic input terminal (Note 1)	2.0	-	5.5	V
	Low	VIN(L)	Logic input terminal (Note 1)	-0.5	-	0.8	V
Input Hysteresis		VIN(HYS)	Logic input terminal (Note 1)	-	150	-	mV
Logic Input Terminal Input Current	High	IIN(H)	Measurement logic input terminal: 5 V	35	50	75	μA
	Low	IIN(L)	Measurement logic input terminal: 0 V	-	-	1	μA
LO0/1/2, MO pin output voltage		VOL(MO)	IOL = 5 mA, Output Low	-	0.2	0.5	V
Current Consumption		IM1	Output : Open, in sleep mode	-	0.03	1	μA
		IM2	Output: Open, SLEEP=H, ENABLE=L	-	7.5	12	mA
		IM3	Output : Open (2-phase excitation), SLEEP=H, ENABLE=H Chopping frequency 40 kHz	-	10.5	15	mA
Motor output leakage current	upper side	IOH	VM = 35 V, VOUT = 0 V	-	-	1	μA
	underside	IOL	VM = VOUT = 35 V	1	-	-	μA
Output current-to-channel error		ΔIOUT1	Output current channel-to-channel error IOUT = 1.0 A	-5	0	5	%
Output set current value error		ΔIOUT2	VM=24V, IOUT = 1.0 A, Ta=25°C	-5	0	5	%
Output transistor Drain-to-source On-resistance (vertical sum)		RON(D-S)	Tj = 25°C IOUT = 2.0 A	-	0.6	0.89	Ω

Note 1: VIN is added to the measurement pin to increase the voltage from 0 V, and the VIN voltage when the motor output terminal voltage changes is specified as VIN(H). In addition, the voltage is lowered, and the VIN voltage when the motor output terminal voltage changes is set to VIN(L). Furthermore, the difference between VIN(H) and VIN(L) is VIN(HYS).

## 11.2. Electrical Characteristics 2 (Ta = -40 to 85°C unless otherwise specified)

table 11.2 Electrical Characteristics

Characteristics	symbol	Test conditions	Min	Typ.	Max	unit
Vref Input Current	IREF	Vref = 3.6 V	-	18	27	μA
Vref attenuation ratio	VREF(GAIN)	Vref = 2.0 V	0.529	0.556	0.583	-
Vref attenuation ratio (with RS)			4.75	5	5.25	-
VREG Supply Voltage	V REG	I REG= 5.0 mA	4.5	5	5.25	V
VREG Current Capability	I REG	VREG = 5.0 V	-	2.5	5	mA
TSD Temperature	TJTSD	-	145	160	175	°C
VM Power-On Reset Voltage	VMPOR		3.8	4.0	4.2	V
VM Power-On Reset Hysteresis	VMPOR(HYS)		-	200	-	mV
Overcurrent detection circuit operating current	ISD	-	2.1	3.0	3.6	A
STOP_DET_VTH Pin threshold setting voltage	VDET	VM=24V	-	0.5	3.0	V

### 11.2.1. Back EMF

While a motor is rotating, there is a timing at which power is fed back to the power supply. At that timing, the motor current recirculates back to the power supply due to the effect of the motor back-EMF.

If the power supply does not have enough sink capability, the power supply and output pins of the device might rise above the rated voltages. The magnitude of the motor back-EMF varies with usage conditions and motor characteristics. It must be fully verified that there is no risk that the device or other components will be damaged or fail due to the motor back-EMF.

### 11.2.2. Handling of ICs

Do not install it incorrectly, including rotating insertion. This can lead to destruction, damage, and deterioration of ICs and equipment.

### 11.2.3. About Overcurrent and Overtemperature Detection

These detection functions temporarily avoid abnormal conditions such as output short circuits, and do not guarantee that the IC will not be destroyed.

If the operation is outside the guaranteed range, these detection functions will not work, and the IC may be destroyed if the output is short-circuited.

The overcurrent detection function is intended for detection of transient short circuits. If the short circuit continues for a long time, it may become overstressed and destroy. Configure the system to release the overcurrent condition promptly.

## 11.3. AC Electrical Characteristics

### 11.3.1. AC Electrical Characteristics 1 (Ta = -40 to 85°C, VM = 24V unless otherwise specified)

table 11.3.1 AC Electrical Characteristics 1

Characteristics	symbol	Test conditions	Min	Typ.	Max	unit
Minimum Clock Pulse Width	tCLK(H)	-	600	-	-	ns
	tCLK(L)	-	600	-	-	ns
Logic Input Signal Minimum Pulse Width <sup>2</sup>	tDTE(H)	-	600	-	-	ns
	tDTE(L)	-	600	-	-	ns
Set-up time	tSU(CLK)	CW_CCW、DMODE0/1/2	600	-	-	ns
Hold Time	tH(CLK)	CW_CCW、DMODE0/1/2	600	-	-	ns
Output transistor Switching characteristics	tr	-	40	70	100	ns
	tf	-	50	80	110	ns
	tpLH(CLK)	-	-	1000	-	ns
	tpHL(CLK)	-	-	1000	-	ns
OSCM oscillation frequency	fOSCM1	ROSC=47 kΩ	1020	1200	1380	kHz
	fOSCM2	When OSCM pin is open or GND is shorted	704	800	944	
Chopping Frequency	fCHOP	fOSCM = 1200 kHz	-	75	-	kHz

11.3.1.1. AC Timing Chart

**TB67S579FTG (Relationship between CLK and Output)**

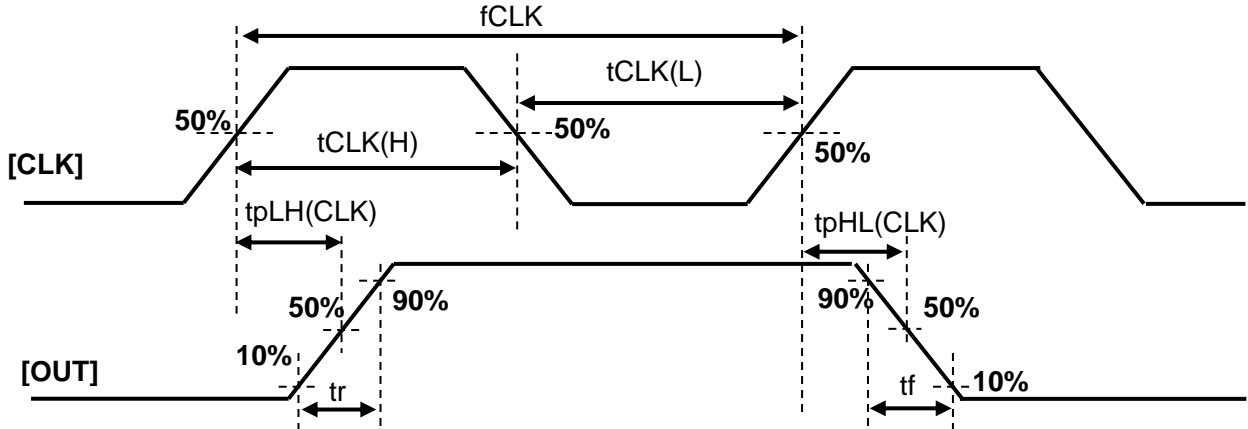

Figure 11.3.1.1 TB67S579FTG (Relationship between CLK and Output)

Note: Timing charts may be simplified for explanatory purposes.

**TB67S579FTG (Relationship between CLK and Other Control Signals)**

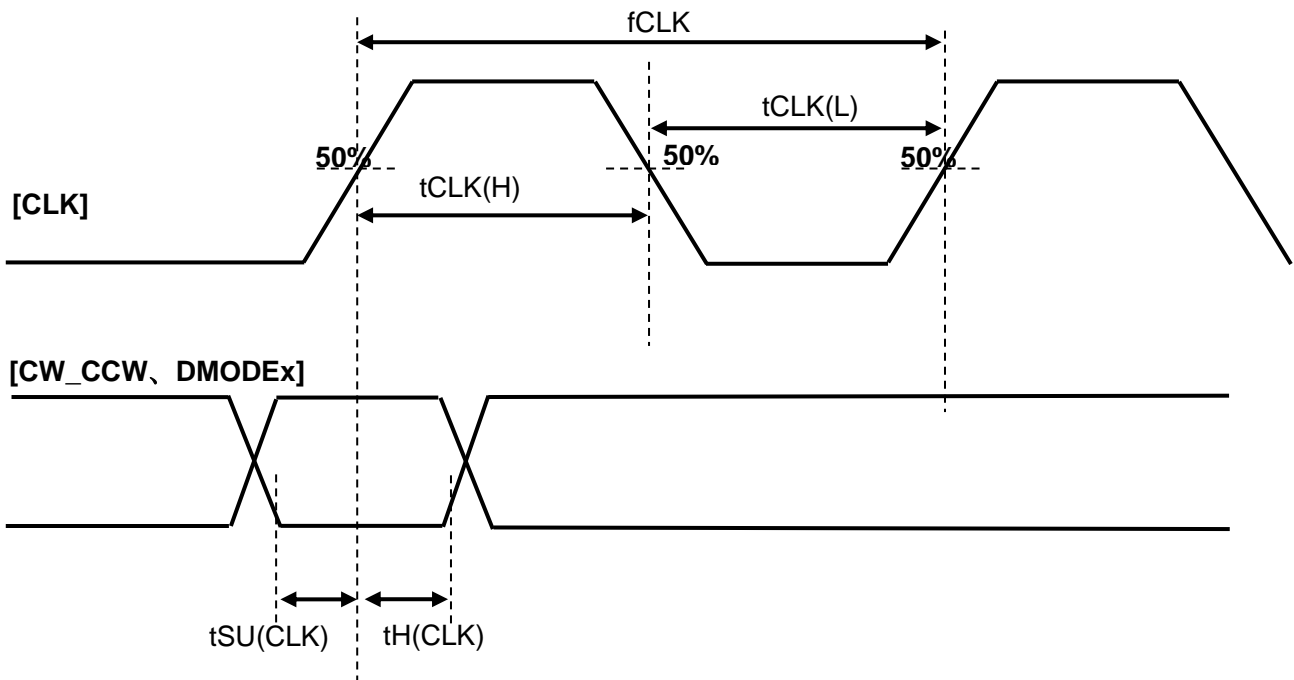

Figure 11.3.1.2 TB67S579FTG (Relationship between CLK and Other Control Signals)

Note: Timing charts may be simplified for explanatory purposes.

## 11.3.2. AC Electrical Characteristics 2 (Ta = -40 to 85°C, VM = 24V unless otherwise specified)

table 11.3.2 AC Electrical Characteristics 2

Characteristics	symbol	Test conditions	Min	Typ.	Max	unit
Serial CLK Frequency	fSCLK	VIN = 3.3 V	-	-	400	kHz
CLK Pulse Width	tscH	VIN = 3.3 V	1.25	-	-	μs
	tscL		1.25	-	-	μs
Serial CLK/DATA Filter Time	tscF	VIN = 3.3 V	0.298	0.313	0.329	μs
Start Condition Time	tst	VIN = 3.3 V	0.625	-	-	μs
Stop Condition Time	ted	VIN = 3.3 V	0.625	-	-	μs
Data setup time	tsu	VIN = 3.3 V	0.625	-	-	μs
Data Hold Time	tsh	VIN = 3.3 V	0.625	-	-	μs

### 11.3.2.1. Timing Chart of Serial I/F AC Characteristics

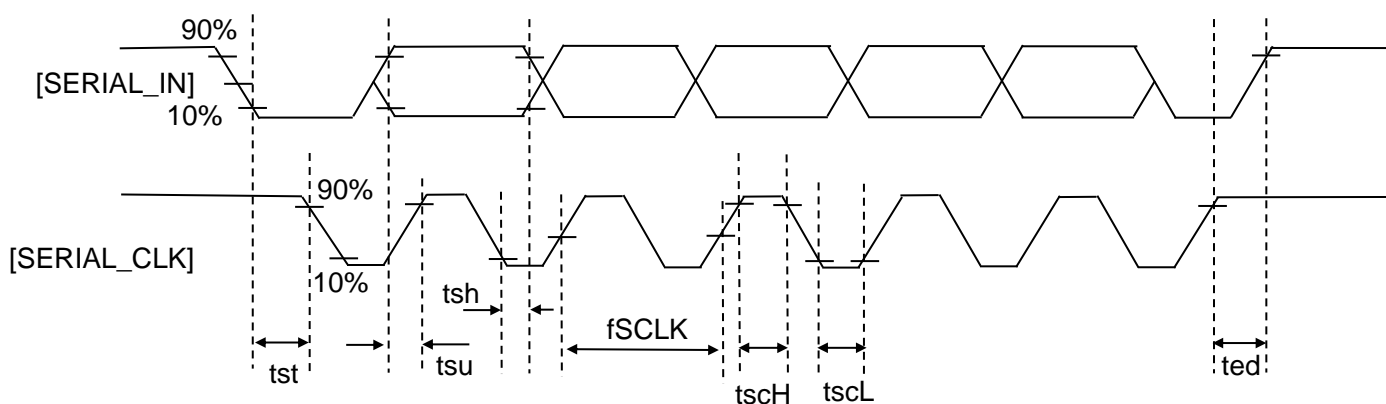
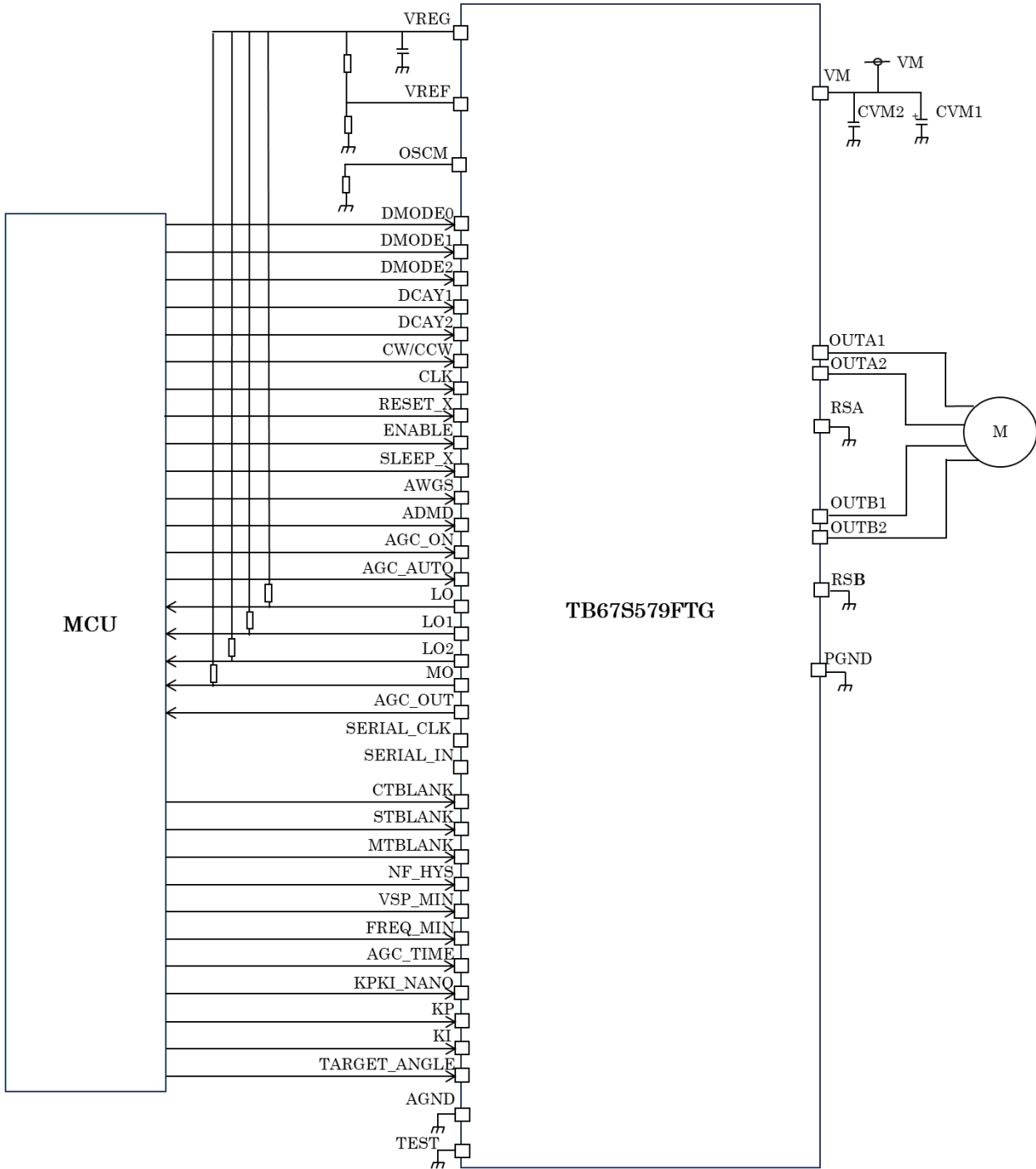

Figure 11.3.2.1 Timing Chart of Serial I/F AC Characteristics

Note: Timing charts may be simplified for explanatory purposes.

**12. Application Circuit Example**



**Figure 12. Examples of Applied Circuits**

For improved heat dissipation, please connect the heat dissipation pad (center part) on the back of the package to the GND of the board.

Some of the application circuit examples may be omitted or simplified to explain the circuit.

## 13. External Drawing

P-VQFN48-0707-0.50-006

Unit: mm

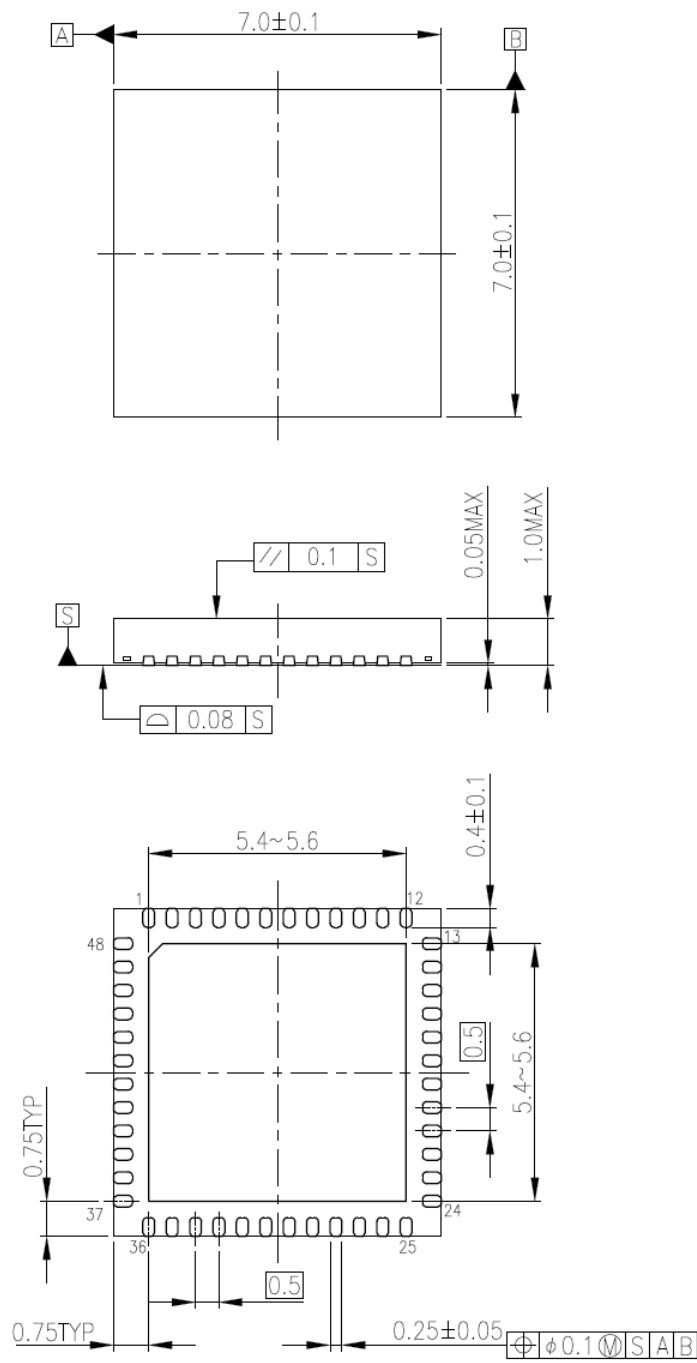

Weight: 0.137 g (Typ.)

## 14. Notes on Contents

### Block Diagrams

Some of the functional blocks, circuits, or constants in the block diagram may be omitted or simplified for explanatory purposes.

### Timing Charts

Timing charts may be simplified for explanatory purposes.

### Application Circuits

The application circuits shown in this document are provided for reference purposes only. Thorough evaluation is required, especially at the mass production design stage. Providing these application circuit examples does not grant a license for industrial property rights.

## 15. IC Usage Considerations

### 15.1.1. Points to Remember on Handling of ICs

#### Over-current detection circuit

Over-current detection circuits (referred to as current limiter circuits) do not necessarily protect ICs under all circumstances. If the over current protection circuits operate against the over current, clear the over current status immediately.

Depending on the method of use and usage conditions, such as exceeding absolute maximum ratings can cause the over current protection circuit to not operate properly or IC breakdown before operation. In addition, depending on the method of use and usage conditions, if over current continues to flow for a long time after operation, the IC may generate heat resulting in breakdown.

#### Thermal shutdown circuit

Thermal shutdown circuits do not necessarily protect ICs under all circumstances. If the thermal shutdown circuits operate against the over temperature, clear the heat generation status immediately.

Depending on the method of use and usage conditions, such as exceeding absolute maximum ratings can cause the thermal shutdown circuit to not operate properly or IC breakdown before operation.

#### Heat radiation design

In using an IC with large current flow such as power amp, regulator or driver, please design the device so that heat is appropriately radiated, not to exceed the specified junction temperature ( $T_j$ ) at any time and condition. These ICs generate heat even during normal use. An inadequate IC heat radiation design can lead to decrease in IC life, deterioration of IC characteristics or IC breakdown. In addition, please design the device taking into consideration the effect of IC heat radiation with peripheral components.

#### Back-EMF

When a motor rotates in the reverse direction, stops or slows down abruptly, a current flow back to the motor's power supply due to the effect of back-EMF. If the current sink capability of the power supply is small, the device's motor power supply and output pins might be exposed to conditions beyond absolute maximum ratings. To avoid this problem, take the effect of back-EMF into consideration in system design.

## 15.2. Precautions and Requests for Use

### 15.2.1.1. Notes on handling of ICs

- (1) The absolute maximum ratings of a semiconductor device are a set of ratings that must not be exceeded, even for a moment. Do not exceed any of these ratings. Exceeding the rating(s) may cause the device breakdown, damage or deterioration, and may result injury by explosion or combustion.
- (2) Do not insert devices in the wrong orientation or incorrectly. Make sure that the positive and negative terminals of power supplies are connected properly. Otherwise, the current or power consumption may exceed the absolute maximum rating, and exceeding the rating(s) may cause the device breakdown, damage or deterioration, and may result injury by explosion or combustion. In addition, do not use any device that is applied the current with inserting in the wrong orientation or incorrectly even just one time.
- (3) Use an appropriate power supply fuse to ensure that a large current does not continuously flow in case of over current and/or IC failure. The IC will fully break down when used under conditions that exceed its absolute maximum ratings, when the wiring is routed improperly or when an abnormal pulse noise occurs from the wiring or load, causing a large current to continuously flow and the breakdown can lead smoke or ignition. To minimize the effects of the flow of a large current in case of breakdown, appropriate settings, such as fuse capacity, fusing time and insertion circuit location, are required.
- (4) If your design includes an inductive load such as a motor coil, incorporate a protection circuit into the design to prevent device malfunction or breakdown caused by the current resulting from the inrush current at power ON or the negative current resulting from the back electromotive force at power OFF. IC breakdown may cause injury, smoke or ignition. Use a stable power supply with ICs with built-in protection functions. If the power supply is unstable, the protection function may not operate, causing IC breakdown. IC breakdown may cause injury, smoke or ignition.

## RESTRICTIONS ON PRODUCT USE

Toshiba Corporation and its subsidiaries and affiliates are collectively referred to as "TOSHIBA". Hardware, software and systems described in this document are collectively referred to as "Product".

- TOSHIBA reserves the right to make changes to the information in this document and related Product without notice.
- This document and any information herein may not be reproduced without prior written permission from TOSHIBA. Even with TOSHIBA's written permission, reproduction is permissible only if reproduction is without alteration/omission.
- Though TOSHIBA works continually to improve Product's quality and reliability, Product can malfunction or fail. Customers are responsible for complying with safety standards and for providing adequate designs and safeguards for their hardware, software and systems which minimize risk and avoid situations in which a malfunction or failure of Product could cause loss of human life, bodily injury or damage to property, including data loss or corruption. Before customers use the Product, create designs including the Product, or incorporate the Product into their own applications, customers must also refer to and comply with (a) the latest versions of all relevant TOSHIBA information, including without limitation, this document, the specifications, the data sheets and application notes for Product and the precautions and conditions set forth in the "TOSHIBA Semiconductor Reliability Handbook" and (b) the instructions for the application with which the Product will be used with or for. Customers are solely responsible for all aspects of their own product design or applications, including but not limited to (a) determining the appropriateness of the use of this Product in such design or applications; (b) evaluating and determining the applicability of any information contained in this document, or in charts, diagrams, programs, algorithms, sample application circuits, or any other referenced documents; and (c) validating all operating parameters for such designs and applications. **TOSHIBA ASSUMES NO LIABILITY FOR CUSTOMERS' PRODUCT DESIGN OR APPLICATIONS.**
- **PRODUCT IS NEITHER INTENDED NOR WARRANTED FOR USE IN EQUIPMENTS OR SYSTEMS THAT REQUIRE EXTRAORDINARILY HIGH LEVELS OF QUALITY AND/OR RELIABILITY, AND/OR A MALFUNCTION OR FAILURE OF WHICH MAY CAUSE LOSS OF HUMAN LIFE, BODILY INJURY, SERIOUS PROPERTY DAMAGE AND/OR SERIOUS PUBLIC IMPACT ("UNINTENDED USE").** Except for specific applications as expressly stated in this document, Unintended Use includes, without limitation, equipment used in nuclear facilities, equipment used in the aerospace industry, Class 3 medical devices, equipment used for automobiles, and military vehicles and munitions. **IF YOU USE PRODUCT FOR UNINTENDED USE, TOSHIBA ASSUMES NO LIABILITY FOR PRODUCT.** For details, please contact your TOSHIBA sales representative or contact us via our website.
- Do not disassemble, analyze, reverse-engineer, alter, modify, translate or copy Product, whether in whole or in part.
- Product shall not be used for or incorporated into any products or systems whose manufacture, use, or sale is prohibited under any applicable laws or regulations.
- The information contained herein is presented only as guidance for Product use. No responsibility is assumed by TOSHIBA for any infringement of patents or any other intellectual property rights of third parties that may result from the use of Product. No license to any intellectual property right is granted by this document, whether express or implied, by estoppel or otherwise.
- **ABSENT A WRITTEN SIGNED AGREEMENT, EXCEPT AS PROVIDED IN THE RELEVANT TERMS AND CONDITIONS OF SALE FOR PRODUCT, AND TO THE MAXIMUM EXTENT ALLOWABLE BY LAW, TOSHIBA (1) ASSUMES NO LIABILITY WHATSOEVER, INCLUDING WITHOUT LIMITATION, INDIRECT, CONSEQUENTIAL, SPECIAL, OR INCIDENTAL DAMAGES OR LOSS, INCLUDING WITHOUT LIMITATION, LOSS OF PROFITS, LOSS OF OPPORTUNITIES, BUSINESS INTERRUPTION AND LOSS OF DATA, AND (2) DISCLAIMS ANY AND ALL EXPRESS OR IMPLIED WARRANTIES AND CONDITIONS RELATED TO SALE, USE OF PRODUCT, OR INFORMATION, INCLUDING WARRANTIES OR CONDITIONS OF MERCHANTABILITY, FITNESS FOR A PARTICULAR PURPOSE, ACCURACY OF INFORMATION, OR NONINFRINGEMENT.**
- Do not use or otherwise make available Product or related software or technology for any military purposes, including without limitation, for the design, development, use, stockpiling or manufacturing of nuclear, chemical, or biological weapons or missile technology products (mass destruction weapons). Product and related software and technology may be controlled under the applicable export laws and regulations including, without limitation, the Japanese Foreign Exchange and Foreign Trade Law and the U.S. Export Administration Regulations. Export and re-export of Product or related software or technology are strictly prohibited except in compliance with all applicable export laws and regulations.
- Please contact your TOSHIBA sales representative for details as to environmental matters such as the RoHS compatibility of Product. Please use Product in compliance with all applicable laws and regulations that regulate the inclusion or use of controlled substances, including without limitation, the EU RoHS Directive. **TOSHIBA ASSUMES NO LIABILITY FOR DAMAGES OR LOSSES OCCURRING AS A RESULT OF NONCOMPLIANCE WITH APPLICABLE LAWS AND REGULATIONS.**

Toshiba Electronic Devices & Storage Corporation

<https://toshiba.semicon-storage.com/>